

Power transmission technology

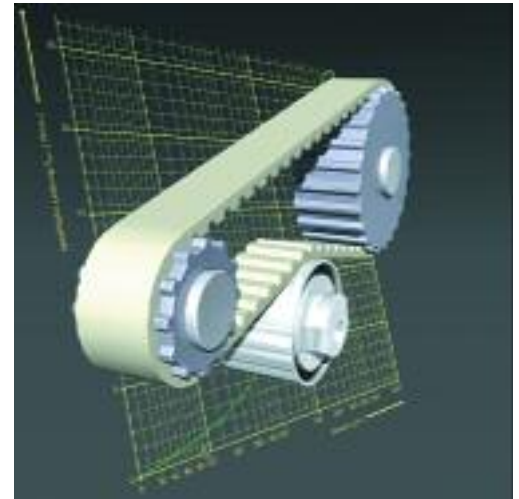

	Page
General informations	
Review of product and performance	38
The E tension member39	
AT GEN III / ATP GEN III	40
Calculation example	42
AT high performance timing belt - endless	
AT 3 GEN III (SFX)	44
AT 3 (SFX)	46
AT 5 GEN III (SFX)	48
AT 5, AT 5-E, AT 5-DL-E, AT 5-DR-E (SFX / BFX)	50 / 52
AT 10 GEN III (SFX)	54
AT 10, AT 10-DL AT 10-DR, AT 10-T (SFX / BFX)	56 / 58
AT 20, AT 20-T (SFX / BFX)	60 / 62
AT high performance timing belt - endless	
ATP 10 GEN III (SFX)	64
ATP 10, ATP 10-DL (SFX / BFX)	66 / 68
ATP 15, ATP 15-DL (SFX / BFX)	70 / 72
Self-guiding timing belts - endless	
BAT 10 (BFX)	74
BATK 10 (BFX)	76
SFAT 10 (BFX)	78
SFAT 15 (BFX)	80
SFAT 20 (BFX)	82
ATK 5 K6-E (BFX)	84
ATK 10 K6, ATK 10 K6-DL, ATK 10 K6-DR (BFX)	86
TK 5 K6 (BFX)	88
TK 10 K6 (BFX)	90
TK 10 K13 (BFX)	92
T standard timing belts - endless	
T 2 (SFX)	94
T 2.5, T 2.5-DL (SFX)	96
T 5, T 5-DL, T 5-DR (SFX / BFX)	98 / 100
T 10, T 10-DL, T 10-DR, T 10-T (SFX / BFX)	102 / 104
T 20, T 20-DL, T 20-DR, T 20-T (SFX / BFX)	106 / 108

	Page
Imperial timing belts - endless	
M (MXL) (SFX)	110
XL (BFX)	112
L (BFX)	114
H, H-DL, H-DR, H-T (BFX)	116
XH (BFX)	118
F flat belts - endless	
F 2 (BFX)	120
F, AF, BF, CF, DF (SFX)	121
Timing belts with special profiles - endless	
K 1, K 1.5 (SFX)	122
V (incl. imperial) (SFX)	124

AT 3

Power transmission: ≤ 5 kW
 Rotational speed: approx. 20000 rpm
 Peripheral speed: approx. 80 ms^{-1}
 Synchronous pulleys: from $t=15$

Applications (example): small power drives ,
 Handling technology

AT 5

Power transmission: ≤ 15 kW
 Rotational speed: approx. 10000 rpm
 Peripheral speed: approx. 80 ms^{-1}
 Synchronous pulleys: from $t=15$

Applications (example): Machine tools, pumps,
 textile machinery

**AT 10; BAT 10; SFAT 10;
 ATK 10 K6**

Power transmission: ≤ 70 kW
 Rotational speed: approx. 10000 rpm
 Peripheral speed: approx. 60 ms^{-1}
 Synchronous pulleys: from $t=15$
 Applications (example): Construction machines,
 pumps, paper-making machines, compressors
 compactors, textile machines, Roller-table
 drives

SFAT 15

Power transmission: ≤ 135 kW
 Rotational speed: approx. 8000 rpm
 Peripheral speed: approx. 48 ms^{-1}
 Synchronous pulleys: from $t=20$

Applications (example): Construction machines,
 pumps, paper-making machines, compressors/
 compactors

ATP 10

Power transmission: ≤ 100 kW
 Rotational speed: approx. 10000 rpm
 Peripheral speed: approx. 60 ms^{-1}
 Synchronous pulleys: from $t=15$

Applications (example): Sanding machinery,
 Power drives, Machine tools

ATP 15

Power transmission: possible beyond 200 kW
 Rotational speed: approx. 10000 rpm
 Peripheral speed: approx. 50 ms^{-1}
 Synchronous pulleys: from $t=20$

Applications (example): Power drives, Machine
 tools

AT 20; SFAT 20

Power transmission: possible beyond 200 kW
 Rotational speed: approx. 6500 rpm
 Peripheral speed: approx. 40 ms^{-1}
 Synchronous pulleys: from $t=18$

Applications (example): Heavy-duty drives,
 Textile machinery,
 Printing machinery,
 Machine tools

K 1.5; T 2; M; T 2.5

Power transmission: $\leq 0,5$ kW
 Rotational speed: approx. 20000 rpm
 Peripheral speed: approx. 80 ms^{-1}
 Synchronous pulleys: from $t=10$

Applications (example): Precision machine drives,
 Film camera drives,
 Positioning drives

T 5; XL

Power transmission: ≤ 5 kW
 Rotational speed: approx. 10000 rpm
 Peripheral speed: approx. 80 ms^{-1}
 Synchronous pulleys: from $t=10$

Applications (example): Office machinery,
 Do-It-Yourself units,
 Positioning and
 regulating drives

T 10; L; H

Power transmission: ≤ 30 kW
 Rotational speed: approx. 10000 rpm
 Peripheral speed: approx. 60 ms^{-1}
 Synchronous pulleys: from $t=12$

Applications (example): Machine tools, Main and
 subsidiary drives, textile machines, Printing
 machinery

T 20; XH

Power transmission: up to approx. 100 kW
 Rotational speed: approx. 6500 rpm
 Peripheral speed: approx. 40 ms^{-1}
 Synchronous pulleys: from $t=15$

Applications (example): Heavy construction
 machinery, Paper machinery, pumps,
 compressors compactors,
 Textile machinery

Remark:

Special timing belt designs allow the rpm and
 peripheral speed parameters to be increased.

Highly flexible tension inserts - the E steel cord tension member

The thinner the single wire, the more flexible the overall tension member! This interrelation led us to develop BRECO[®] BRECOFLEX[®] and SYNCHROFLEX[®] TIMING BELTS with E tension members.

In the E tension member the tension member cross-section is distributed to a lot more thin individual wires and, therefore, the bending fatigues are markedly lower in the individual wires. The advantage of the E tension members is a higher flexibility.

This is especially important, when smaller mounting dimensions for pulleys and tension rollers are required. The minimum number of teeth and/or minimum diameter of the pulleys can be fallen below up to 30% compared with standard tension members.

Timing belts with E tension members are recommended for multi-shaft drive with frequent bends.

Application informations: For intended application under extreme conditions please contact our technical department for advise.

Steel cord tension members encapsulated in polyurethane:



The thinner the individual wire the more flexible the whole timing belt

Summary:

- thinner individual wires in the steel cord
- higher dynamic capabilities
- extremely high bonding and bending fatigue strength
- smaller pulley and tension roller diameter
- no correction of the synchronising pulleys are necessary

Available versions:

- for the pitches AT 3 (standard), AT 5 (BRECOFLEX standard), AT 10, ATP10, T 5, T 10, T 20
- Belt lengths respectively to the delivery range
- Synchronising pulleys respectively to the delivery range
- Calculation analog to the standard tension member

Timing belts with E tension members, minimum numbers of teeth:

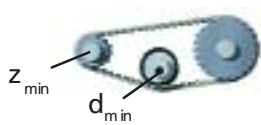
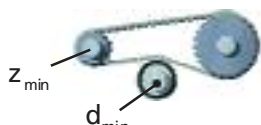
Drive type			AT 3	AT 5	AT 10	T 5	T 10	T 20
			(Standard)	(BFX Standard)	ATP 10			
without contraflexure 	Synchronising pulley	z_{min}	15	12	12	10	10	12
	Tension roller (smooth), running on teeth	d_{min} [mm]	20	18	50	18	50	80
with contraflexure 	Synchronising pulley	z_{min}	20	20	20	12	15	20
	Tension roller (smooth), running on the back of the belt	d_{min} [mm]	20	50	80	18	50	120

AT / ATP high performance timing belt - GEN III

SYNCHROFLEX® TIMING BELT (SFX)

AT GEN III / ATP GEN III



Power transmission
technology

**Each generation is different.
GEN III is better!**

The intensive development work on the SYNCHROFLEX® TIMING BELTS of the AT and ATP series emphasizing on the power drives has proven successful, because an increase in power transmission of up to 25% of the new generation compared to the AT / ATP standard could be achieved. A further economical plus: All SYNCHROFLEX® TIMING BELTS GEN III are suitable for application with standard AT / ATP synchronising pulleys.

For all partners in the Mulco Europe EWIV progress means to provide the best possible solution for each product down to the smallest technical detail. This is achieved for the new SYNCHROFLEX® GEN III of the AT and ATP series by the use of a two-filament tension member arrangement and with a higher density.

A powerful basis

The combination of high tensile steel cord tension members and wear resistant polyurethane forms the basis for dimensionally stable and high resistant polyurethane timing belts. A technology convincing with excellent product properties.

- constant length, no post-elongation
- high dimensional stability
- Transmission of high torques
- quiet run
- maintenance-free
- no timing belt lubrication
- high resistance against mechanical and chemical influences

The new high performance polyurethane is distinguished by numerous performance improvements. Thus, amongst others, it is possible to consider a higher number of load bearing teeth in the calculation by an increased hardness.

SYNCHROFLEX[®]-GEN III - a higher power transmission of up to 25% compared to the AT / ATP standard:

- due to closer wound cords F_{adm} to max. +45%
- strongly reduced wandering-off tendency / optimised straight run due to two-filament tension members and balanced twist direction in S and Z design
- reduced friction at the flange
- minimised running noise with reduced belt width and equal performance
- F_{spec} +25%
- longer longevity
- Circumferential force distribution to a number of load bearing teeth increased by up to 30%
- Application up to 100°C
 (for performance values in the limit range please contact us)

Two-filament tension member arrangement New high performance polyurethane

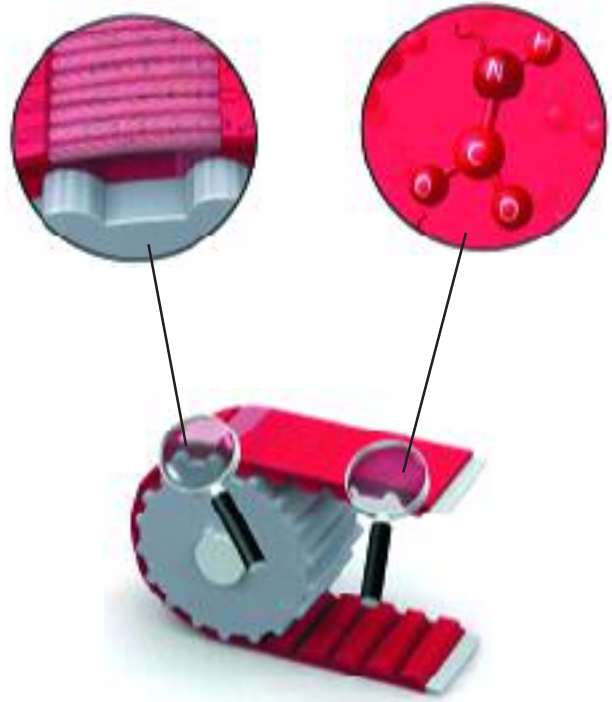

Power transmission technology



SYNCHROFLEX[®] standard

SYNCHROFLEX[®]-GEN III

Calculation example

Task

A roll table drive must be designed for heavy conveying duties. Under start-up conditions the 2.5 times the running torque is exerted on the timing belt.

The application conditions are:

Given:	Power	$P = 10$	kW
	Nominal speed	$n = 800$	min^{-1}
	Start-up torque	$M = 300$	Nm
	Transmission, number of teeth	$i = 1$	$z = 25$
	Centre distance	$a = 625$	mm

Required: The timing belt pitch is to be determined and the belt width is to be designed.

Formulae: $b = \frac{100 \cdot M}{z_1 \cdot z_e \cdot M_{\text{spec}}} \quad M[\text{Nm}]$

$$b = \frac{1000 \cdot P}{z_1 \cdot z_e \cdot P_{\text{spec}}} \quad P[\text{kW}]$$

$$F_U = \frac{2 \cdot 10^3 \cdot M}{d_0} \quad F_U [\text{N}]$$

$$L = 2 \cdot a + z \cdot t \quad [\text{mm}]$$

$$d_0 = \frac{z \cdot t}{\pi} \quad [\text{mm}]$$

How to proceed

Belt length: Profile preselection: AT10. Calculation of the belt length with formula:

$$\begin{aligned} L &= 2 \cdot a + z \cdot t \\ &= 2 \cdot 625 + 25 \cdot 10 \\ &= \underline{1500 \text{ mm}} \end{aligned}$$

Calculation of the belt width:

1. Tooth shear strength

In the calculation it will be used $z_e = 12$ (see basis of calculation).

Calculation of the belt width with the nominal speed of the power equations.

$$\begin{aligned} b &= \frac{1000 \cdot P}{z_1 \cdot z_e \cdot P_{\text{spec}}} \\ &= \frac{1000 \cdot 10}{25 \cdot 12 \cdot 6,96} \\ &= 4,79 \text{ cm} = \underline{47,9 \text{ mm}} \end{aligned}$$

Calculation of the belt width under start-up torque when rotational speed $n = 0$.

$$\begin{aligned} b &= \frac{100 \cdot M}{z_1 \cdot z_e \cdot M_{\text{spec}}} \\ &= \frac{100 \cdot 300}{25 \cdot 12 \cdot 11,70} \\ &= 8,54 \text{ cm} = \underline{85,4 \text{ mm}} \end{aligned}$$

The belt width is to be determined from the least favourable load conditions.

Selected: the next larger standard belt width $\underline{b = 100 \text{ mm}}$.

2. Tension cord strength

The corresponding circumferencial force can be calculated from the general data supplied:

$$\begin{aligned} F_u &= \frac{2 \cdot 10^3 \cdot M}{d_0} \\ &= \frac{2 \cdot 10^3 \cdot M}{79,58} = \underline{7539 \text{ N} < 16000 \text{ N}} \end{aligned}$$

The tabular value F_{adm} for AT 10 with 100 mm belt width is 16000 N. Thus, there is a sufficient tension member safety factor.

3. Flexibility

The design is a drive „without contraflexure“. The minimum number of teeth according to the table is adhered to.

Result: The drive is correctly designed with a belt width of 100 mm. A maintenance-free operation can be expected.

Ordering code: SYNCHROFLEX TIMING BELT 100 AT 10 / 1500

AT high performance timing belt - endless

SYNCHROFLEX® TIMING BELT (SFX)

AT 3 GEN III

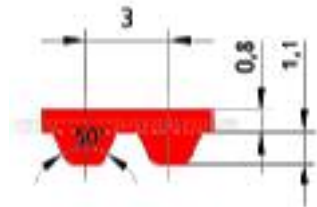

High performance AT profile with metric pitches and trapezoidal teeth

Standard version:

- single-sided
- High performance polyurethane in red colour
- Steel cord tension members with high density
- Steel cord tension members in two-filament construction
- Steel cord tension members in highly flexible construction
- **FA:** with strengthened back of the belt
- **FN:** with profiles on the back of the belt

Product range*

Type	Number	Type	Number
GEN III / Length	of teeth	GEN III / Length	of teeth
AT 3 / 150	50	AT 3 / 816	272
AT 3 / 201	67	AT 3 / 816 FA	272
AT 3 / 252	84	AT 3 / 900	300
AT 3 / 267	89	AT 3 / 1011	337
AT 3 / 270	90		
AT 3 / 300	100		
AT 3 / 351	117		
AT 3 / 399	133		
AT 3 / 417	139		
AT 3 / 450	150		
AT 3 / 501	167		
AT 3 / 549	183		
AT 3 / 600	200		
AT 3 / 639	213		
AT 3 / 648 FN24	216		

Preferred belt width*

b [mm]: 6 10 16 25 32

*Other dimension upon request.

Order example

SYNCHROFLEX®-TIMING BELT 10 AT3 / 450 GEN III

Belt width in mm _____
 Type / Pitch _____
 Belt length in mm _____
 Specification Generation III _____

Technical data of the SYNCHROFLEX® TIMING BELT

AT 3 GEN III

Belt width b[cm]

$$b = \frac{F_U}{z_e \cdot F_{U\text{spec}}} \quad F_U [\text{N}]$$

$$b = \frac{100 \cdot M}{z_1 \cdot z_e \cdot M_{\text{spec}}} \quad M [\text{Nm}]$$

$$b = \frac{1000 \cdot P}{z_1 \cdot z_e \cdot P_{\text{spec}}} \quad P [\text{kW}]$$

Drive load bearing characteristics
with given belt width [cm]

$$F_U = F_{U\text{spec}} \cdot z_e \cdot b \quad [\text{N}]$$

$$M = \frac{M_{\text{spec}} \cdot z_1 \cdot z_e \cdot b}{100} \quad [\text{Nm}]$$

$$P = \frac{P_{\text{spec}} \cdot z_1 \cdot z_e \cdot b}{1000} \quad [\text{kW}]$$

intermeshing number of teeth

$$z_{e\text{max}} = 16$$

$$z_e = \frac{z_1}{180} \arccos \frac{t \cdot (z_2 - z_1)}{2\pi \cdot a}$$



1. Tooth shear strength (specific belt tooth load bearing)

R.p.m. n [rpm]	$F_{U\text{spec}}$ [N/cm]	M_{spec} [Ncm/cm]	P_{spec} [W/cm]	R.p.m. n [rpm]	$F_{U\text{spec}}$ [N/cm]	M_{spec} [Ncm/cm]	P_{spec} [W/cm]
0	40,43	1,93	0,00	2400	24,66	1,18	2,96
20	40,00	1,91	0,04	2500	24,40	1,17	3,05
40	39,60	1,89	0,08	2600	24,14	1,15	3,14
60	39,21	1,87	0,12	2800	23,63	1,13	3,31
80	38,85	1,86	0,16	3000	23,16	1,11	3,47
100	38,50	1,84	0,19	3200	22,71	1,09	3,63
150	37,70	1,80	0,28	3400	22,30	1,07	3,79
200	36,98	1,77	0,37	3600	21,90	1,05	3,94
300	35,69	1,70	0,54	3800	21,53	1,03	4,09
400	34,60	1,65	0,69	4000	21,16	1,01	4,23
500	33,64	1,61	0,84	4500	20,34	0,97	4,58
600	32,79	1,57	0,98	5000	19,59	0,94	4,90
700	32,03	1,53	1,12	5500	18,90	0,90	5,20
800	31,34	1,50	1,25	6000	18,28	0,87	5,48
900	30,70	1,47	1,38	6500	17,69	0,85	5,75
1000	30,11	1,44	1,51	7000	17,15	0,82	6,00
1100	29,56	1,41	1,63	7500	16,65	0,80	6,24
1200	29,05	1,39	1,74	8000	16,18	0,77	6,47
1300	28,58	1,36	1,86	8500	15,74	0,75	6,69
1400	28,13	1,34	1,97	9000	15,31	0,73	6,89
1500	27,70	1,32	2,08	9500	14,91	0,71	7,08
1600	27,30	1,30	2,18	10000	14,54	0,69	7,27
1700	26,91	1,29	2,29	12000	13,19	0,63	7,91
1800	26,55	1,27	2,39	15000	11,53	0,55	8,64
1900	26,20	1,25	2,49	18000	10,16	0,49	9,15
2000	25,88	1,24	2,59	20000	9,38	0,45	9,37
2200	25,25	1,21	2,78				

2. Tension cord strength (permitted tensile force of the belt F_{adm}), belt weight

Belt width	b	[mm]	6	10	16	25	32
SYNCHROFLEX®	F_{adm}	[N]	330	599	1002	1608	2079
Belt weight	AT 3 GEN III	[kg/m]	0,016	0,026	0,042	0,065	0,083

3. Flexibility (Minimum numbers of teeth, minimum diameter)

Drive type	SFX AT 3 GEN III	
without contraflexure	Synchronising pulley z_{min}	15
	Tension roller (smooth), running on teeth d_{min} [mm]	20
with contraflexure	Synchronising pulley z_{min}	20
	Tension roller (smooth), running on the back of the belt d_{min} [mm]	20

AT high performance timing belt - endless

SYNCHROFLEX[®] TIMING BELT (SFX)

AT 3

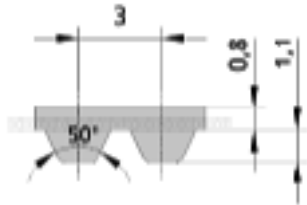

High performance AT profile with metric pitches and trapezoidal teeth.

The technical data refer to standard casting polyurethane and E steel cord tension members.

Available versions:

- single-sided
- with reinforced design
- with Aramid tension member
- Polyurethane special materials upon request antistatic, coloured, mechanical reworked
- **FA:** with reinforced back of the belt
- **FN:** with profiles on the back of the belt

Type /Length	Number of teeth	Type/ Length	Number of teeth
AT 3 / 150	50	AT 3 / 816	272
AT 3 / 201	67	AT 3 / 816 FA	272
AT 3 / 252	84	AT 3 / 900	300
AT 3 / 267	89	AT 3 / 1011	337
AT 3 / 270	90		
AT 3 / 300	100		
AT 3 / 351	117		
AT 3 / 399	133		
AT 3 / 417	139		
AT 3 / 450	150		
AT 3 / 501	167		
AT 3 / 549	183		
AT 3 / 600	200		
AT 3 / 639	213		
AT 3 / 648 FN24	216		

Preferred belt width

b [mm]: 6 10 16 25 32

In-between belt widths are available

Other dimension upon request.

Order example

SYNCHROFLEX[®]-TIMING BELT 10 AT3 / 450

Belt width in mm

Type / Pitch

Belt length in mm

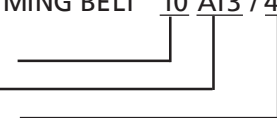

Technical data of the SYNCHROFLEX® TIMING BELT

AT 3

Belt width b[cm]

$$b = \frac{F_U}{z_e \cdot F_{U\text{spec}}} \quad F_U [\text{N}]$$

$$b = \frac{100 \cdot M}{z_1 \cdot z_e \cdot M_{\text{spec}}} \quad M [\text{Nm}]$$

$$b = \frac{1000 \cdot P}{z_1 \cdot z_e \cdot P_{\text{spec}}} \quad P [\text{kW}]$$

Drive load bearing characteristics

with given belt width [cm]

$$F_U = F_{U\text{spec}} \cdot z_e \cdot b \quad [\text{N}]$$

$$M = \frac{M_{\text{spec}} \cdot z_1 \cdot z_e \cdot b}{100} \quad [\text{Nm}]$$

$$P = \frac{P_{\text{spec}} \cdot z_1 \cdot z_e \cdot b}{1000} \quad [\text{kW}]$$

intermeshing number of teeth

$$z_{e\text{max}} = 12$$

$$z_e = \frac{z_1}{180} \cdot \arccos \frac{t \cdot (z_2 - z_1)}{2\pi \cdot a}$$

1. Tooth shear strength (specific belt tooth load bearing)

R.p.m. n [rpm]	F _{U spec} [N/cm]	M _{spec} [Ncm/cm]	P _{spec} [W/cm]	R.p.m. n [rpm]	F _{U spec} [N/cm]	M _{spec} [Ncm/cm]	P _{spec} [W/cm]
0	32,34	1,544	0,000	2200	20,20	0,964	2,222
20	32,00	1,528	0,032	2400	19,73	0,942	2,367
40	31,68	1,513	0,063	2500	19,52	0,932	2,440
60	31,37	1,498	0,094	2600	19,31	0,922	2,510
80	31,08	1,484	0,124	2800	18,90	0,902	2,646
100	30,80	1,471	0,154	2880	18,75	0,895	2,700
150	30,16	1,440	0,226	3000	18,53	0,885	2,779
200	29,58	1,412	0,296	3200	18,17	0,868	2,907
300	28,55	1,363	0,428	3400	17,84	0,852	3,033
400	27,68	1,322	0,554	3600	17,52	0,837	3,153
500	26,91	1,285	0,673	3800	17,22	0,822	3,272
600	26,23	1,252	0,787	4000	16,93	0,808	3,386
700	25,62	1,223	0,897	4500	16,27	0,777	3,660
730	25,45	1,215	0,929	5000	15,67	0,748	3,917
800	25,07	1,197	1,003	5500	15,12	0,722	4,158
900	24,56	1,173	1,105	6000	14,62	0,698	4,386
1000	24,09	1,150	1,204	6500	14,15	0,676	4,598
1100	23,65	1,129	1,301	7000	13,72	0,655	4,802
1200	23,24	1,110	1,394	7500	13,32	0,636	4,995
1300	22,86	1,091	1,486	8000	12,94	0,618	5,176
1400	22,50	1,074	1,575	8500	12,59	0,601	5,350
1460	22,29	1,064	1,627	9000	12,25	0,585	5,512
1500	22,16	1,058	1,662	9500	11,93	0,570	5,666
1600	21,84	1,043	1,747	10000	11,63	0,555	5,815
1700	21,53	1,028	1,830	12000	10,55	0,504	6,330
1800	21,24	1,014	1,911	15000	9,22	0,440	6,914
1900	20,96	1,001	1,991	18000	8,13	0,388	7,316
2000	20,70	0,988	2,070	20000	7,50	0,358	7,499

2. Tension cord strength (permitted tensile force of the belt F_{adm}), belt weight

Belt width	b	[mm]	6	10	16	25	32
SYNCHROFLEX®	F _{adm}	[N]	190	380	646	1102	1406
Belt weight	AT 3	[kg/m]	0,014	0,023	0,037	0,058	0,074

3. Flexibility (Minimum numbers of teeth, minimum diameter)

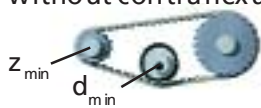
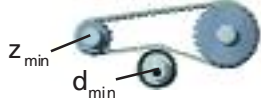
Drive type	SFX AT 3		
without contraflexure	Synchronising pulley	z _{min}	15
	Tension roller (smooth), running on teeth	d _{min} [mm]	20
with contraflexure	Synchronising pulley	z _{min}	20
	Tension roller (smooth), running on the back of the belt	d _{min} [mm]	20

AT high performance timing belt - endless

SYNCHROFLEX® TIMING BELT (SFX)

AT 5 GEN III

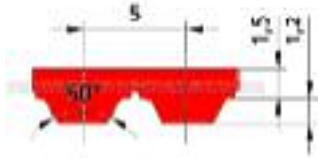

High performance AT profile with metric pitches and trapezoidal teeth

Standard version:

- single-sided
 - High performance polyurethane in red colour
 - Steel cord tension members with high density
 - Steel cord tension members in two-filament construction
 - Steel cord tension members in highly flexible construction
- **FA:** with reinforced back of the belt

Product range*

Type GEN III / Length	Number of teeth	Type GEN III / Length	Number of teeth
AT 5 / 225	45	AT 5 / 720	144
AT 5 / 255	51	AT 5 / 750	150
AT 5 / 260	52	AT 5 / 780	156
AT 5 / 280	56	AT 5 / 825	165
AT 5 / 300	60	AT 5 / 860	172
AT 5 / 330	66	AT 5 / 875	175
AT 5 / 340	68	AT 5 / 900	180
AT 5 / 375	75	AT 5 / 920	184
AT 5 / 390	78	AT 5 / 975	195
AT 5 / 420	84	AT 5 / 1050	210
AT 5 / 450	90	AT 5 / 1125	225
AT 5 / 455	91	AT 5 / 1230	246
AT 5 / 480	96	AT 5 / 1500	300
AT 5 / 490	98	AT 5 / 1750	350
AT 5 / 500	100	AT 5 / 2000	400
AT 5 / 525	105	AT 5 / 3350 FA	670
AT 5 / 545	109	AT 5 / 3800 FA	760
AT 5 / 600	120		
AT 5 / 610	122		
AT 5 / 620	124		
AT 5 / 630	126		
AT 5 / 660	132		
AT 5 / 670	134		
AT 5 / 690	138		
AT 5 / 710	142		

Preferred belt width*

b [mm]: 6 10 16 25 32 50 75 100

*Other dimension upon request.

Order example

SYNCHROFLEX®-TIMING BELT 50 AT5 / 450 GEN III

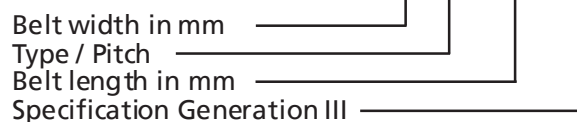

Technical data of the SYNCHROFLEX® TIMING BELT

AT 5 GEN III

Belt width b[cm]

$$b = \frac{F_U}{z_e \cdot F_{U\text{spec}}} \quad F_U [\text{N}]$$

$$b = \frac{100 \cdot M}{z_1 \cdot z_e \cdot M_{\text{spec}}} \quad M [\text{Nm}]$$

$$b = \frac{1000 \cdot P}{z_1 \cdot z_e \cdot P_{\text{spec}}} \quad P [\text{kW}]$$

Drive load bearing characteristics
with given belt width [cm]

$$F_U = F_{U\text{spec}} \cdot z_e \cdot b \quad [\text{N}]$$

$$M = \frac{M_{\text{spec}} \cdot z_1 \cdot z_e \cdot b}{100} \quad [\text{Nm}]$$

$$P = \frac{P_{\text{spec}} \cdot z_1 \cdot z_e \cdot b}{1000} \quad [\text{kW}]$$

intermeshing number of teeth

$$z_{\text{emax}} = 16$$

$$z_e = \frac{z_1}{180} \cdot \arccos \frac{t \cdot (z_2 - z_1)}{2\pi \cdot a}$$

1. Tooth shear strength (specific belt tooth load bearing)



R.p.m. n [rpm]	F _{U spec} [N/cm]	M _{spec} [Ncm/cm]	P _{spec} [W/cm]	R.p.m. n [rpm]	F _{U spec} [N/cm]	M _{spec} [Ncm/cm]	P _{spec} [W/cm]
0	44,13	3,51	0,00	2400	26,00	2,07	5,20
20	43,63	3,48	0,07	2600	25,38	2,02	5,50
40	43,13	3,44	0,14	2800	24,80	1,97	5,79
60	42,63	3,40	0,21	3000	24,28	1,93	6,06
80	42,25	3,36	0,28	3200	23,76	1,89	6,34
100	41,88	3,33	0,35	3400	23,30	1,85	6,60
200	40,00	3,19	0,67	3600	22,85	1,82	6,85
300	38,63	3,08	0,96	3800	22,41	1,78	7,10
400	37,25	2,96	1,24	4000	22,01	1,85	7,34
500	36,25	2,88	1,51	4500	21,08	1,68	7,90
600	35,25	2,80	1,76	5000	20,23	1,61	8,43
700	34,28	2,74	2,00	5500	19,45	1,55	8,91
800	33,50	2,68	2,24	6000	18,75	1,49	9,38
900	32,88	2,61	2,46	6500	18,10	1,44	9,80
1000	32,13	2,56	2,68	7000	17,49	1,39	10,20
1100	31,50	2,51	2,89	7500	16,93	1,35	10,58
1200	31,00	2,64	3,10	8000	16,39	1,30	10,93
1300	30,38	2,42	3,30	8500	15,89	1,26	11,25
1400	29,88	2,38	3,49	9000	15,41	1,23	11,55
1500	29,38	2,34	3,68	9500	14,96	1,19	11,84
1600	29,00	2,30	3,86	10000	14,54	1,16	12,11
1700	28,50	2,27	4,04				
1800	28,13	2,24	4,21				
1900	27,75	2,21	4,39				
2000	27,38	2,18	4,56				
2200	26,63	2,12	4,89				

Rotational speeds over 10000 rpm and/or belt speeds over 80 m/s are in need of a special drive design. Please request for our advice.

2. Tension cord strength (permitted tensile force of the belt F_{adm}), belt weight

Belt width	b	[mm]	6	10	16	25	32	50	75	100
SYNCHROFLEX®	F _{adm}	[N]	417	787	1342	2175	2823	4489	6803	9117
Belt weight	AT 5 GEN III	[kg/m]	0,022	0,036	0,058	0,090	0,115	0,180	0,270	0,360

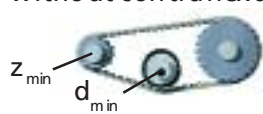
3. Flexibility (Minimum numbers of teeth, minimum diameter)

Drive type	SFX AT 5 GEN III		
without contraflexure 	Synchronising pulley	z _{min}	15
	Tension roller (smooth), running on teeth	d _{min} [mm]	25
with contraflexure 	Synchronising pulley	z _{min}	20
	Tension roller (smooth), running on the back of the belt	d _{min} [mm]	60

AT high performance timing belt - endless

SYNCHROFLEX® TIMING BELT (SFX)

AT 5

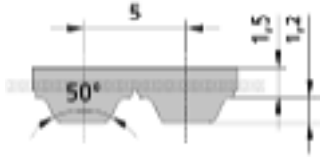

High performance AT profile with metric pitches and trapezoidal teeth.

The technical data refer to standard casting polyurethane and standard steel cord tension members.

Available versions:

- single-sided
- with E tension member for a better flexibility
- with reinforced design
- with Aramid tension member
- Polyurethane special materials upon request
- antistatic, coloured, mechanical reworked
- **FA:** with reinforced back of the belt

Type / length	Number of teeth	Type / length	Number of teeth
AT 5 / 225	45	AT 5 / 720	144
AT 5 / 255	51	AT 5 / 750	150
AT 5 / 260	52	AT 5 / 780	156
AT 5 / 280	56	AT 5 / 825	165
AT 5 / 300	60	AT 5 / 860	172
AT 5 / 330	66	AT 5 / 875	175
AT 5 / 340	68	AT 5 / 900	180
AT 5 / 375	75	AT 5 / 920	184
AT 5 / 390	78	AT 5 / 975	195
AT 5 / 420	84	AT 5 / 1050	210
AT 5 / 450	90	AT 5 / 1125	225
AT 5 / 455	91	AT 5 / 1230	246
AT 5 / 480	96	AT 5 / 1500	300
AT 5 / 490	98	AT 5 / 1750	350
AT 5 / 500	100	AT 5 / 2000	400
AT 5 / 525	105	AT 5 / 3350 FA	670
AT 5 / 545	109	AT 5 / 3800 FA	760
AT 5 / 600	120		
AT 5 / 610	122		
AT 5 / 620	124		
AT 5 / 630	126		
AT 5 / 660	132		
AT 5 / 670	134		
AT 5 / 690	138		
AT 5 / 710	142		

Preferred belt width

b [mm]: 10 16 25 32 50

In-between belt widths are available

Other dimension upon request.

Order example

SYNCHROFLEX®-TIMING BELT 10 AT5 / 450

Belt width in mm _____
 Type / Pitch _____
 Belt length in mm _____

Technical data of the SYNCHROFLEX® TIMING BELT

AT 5

Belt width b[cm]

$$b = \frac{F_U}{z_e \cdot F_{U\text{spec}}} \quad F_U[\text{N}]$$

$$b = \frac{100 \cdot M}{z_1 \cdot z_e \cdot M_{\text{spec}}} \quad M[\text{Nm}]$$

$$b = \frac{1000 \cdot P}{z_1 \cdot z_e \cdot P_{\text{spec}}} \quad P[\text{kW}]$$

Drive load bearing characteristics

with given belt width [cm]

$$F_U = F_{U\text{spec}} \cdot z_e \cdot b \quad [\text{N}]$$

$$M = \frac{M_{\text{spec}} \cdot z_1 \cdot z_e \cdot b}{100} \quad [\text{Nm}]$$

$$P = \frac{P_{\text{spec}} \cdot z_1 \cdot z_e \cdot b}{1000} \quad [\text{kW}]$$

intermeshing number of teeth

$$z_{e\text{max}} = 12$$

$$z_e = \frac{z_1}{180} \cdot \arccos \frac{t \cdot (z_2 - z_1)}{2\pi \cdot a}$$

1. Tooth shear strength (specific belt tooth load bearing)



R.p.m. n [rpm]	F _{U spec} [N/cm]	M _{spec} [Ncm/cm]	P _{spec} [W/cm]	R.p.m. n [rpm]	F _{U spec} [N/cm]	M _{spec} [Ncm/cm]	P _{spec} [W/cm]
0	35,3	2,810	0,000	2800	19,84	1,579	4,63
20	34,9	2,780	0,058	3000	19,42	1,545	4,85
40	34,5	2,750	0,115	3200	19,01	1,513	5,07
60	34,1	2,720	0,171	3400	18,64	1,483	5,28
80	33,8	2,690	0,225	3600	18,28	1,454	5,48
100	33,5	2,660	0,279	3800	17,93	1,427	5,68
200	32,0	2,550	0,534	4000	17,61	1,401	5,87
300	30,9	2,460	0,771	4500	16,86	1,342	6,32
400	29,8	2,370	0,995	5000	16,18	1,288	6,74
500	29,0	2,300	1,207	5500	15,56	1,239	7,13
600	28,2	2,240	1,409	6000	15,00	1,194	7,50
700	27,5	2,190	1,603	6500	14,48	1,152	7,84
800	26,8	2,140	1,789	7000	13,99	1,113	8,16
900	26,3	2,090	1,969	7500	13,54	1,077	8,46
1000	25,7	2,050	2,140	8000	13,11	1,043	8,74
1100	25,2	2,010	2,310	8500	12,71	1,011	9,00
1200	24,8	1,970	2,480	9000	12,33	0,981	9,24
1300	24,3	1,936	2,640	9500	11,97	0,953	9,47
1400	23,9	1,903	2,790	10000	11,63	0,925	9,69
1500	23,5	1,872	2,940				
1600	23,2	1,843	3,090				
1700	22,8	1,816	3,230				
1800	22,5	1,789	3,370				
1900	22,2	1,764	3,510				
2000	21,9	1,740	3,650				
2200	21,3	1,695	3,910				
2400	20,8	1,654	4,160				
2600	20,3	1,615	4,400				

Rotational speeds over 10000 rpm and/ or belt speeds over 80 m/s are in need of a special drive design. Please request for our advice.

2. Tension cord strength (permitted tensile force of the belt F_{adm}), belt weight

Belt width	b	[mm]	6	10	16	25	32	50	75	100
SYNCHROFLEX®	F _{adm}	[N]	350	700	1260	2030	2660	4200	6370	8610
Belt weight	AT 5	[kg/m]	0,020	0,034	0,054	0,085	0,109	0,170	0,255	0,340

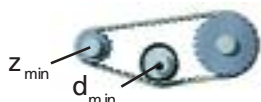
3. Flexibility (Minimum numbers of teeth, minimum diameter)

Drive type	SYNCHROFLEX® AT 5*		
without contraflexure	Synchronising pulley	z _{min}	15
	Tension roller (smooth), running on teeth	d _{min} [mm]	25
with contraflexure	Synchronising pulley	z _{min}	20
	Tension roller (smooth), running on the back of the belt	d _{min} [mm]	60

* Request for advice in limit ranges.

AT high performance timing belt - endless

BRECOFLEX® TIMING BELTS (BFX)

AT 5-E

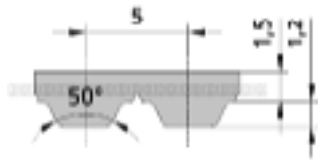

AT 5-DL-E

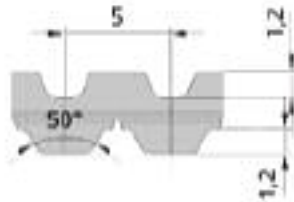

AT 5-DR-E

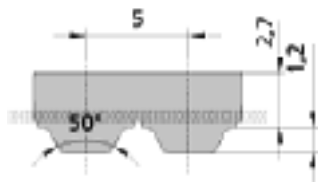

Available endless lengths for AT 5-E

- Preferred lengths refer to table
- Belt lengths smaller than 1100 mm with nylon tooth facing
- under 1075 mm: further lengths upon request
- over 1075 mm: Any number of teeth available, request minimum purchase amount for intermediate lengths.
- over 15,000 mm on request

Available versions:

- **AT 5-E:** As standard: single-sided with E tension members
- **DL-E:** As standard: double-sided over 1075 mm, with E tension member, minimum amount on request, under 1075 mm on request
- **PAZ-E:** Nylon tooth facing, with E tension member
- **DL-PAZ-E:** Nylon facing on double-sided belts, coating is only possible on the inner side, with E tension member, minimum amount on request
- **DR-E, DR-PAZ-E:** reinforced back of the belt, through 1.2 mm larger belt thickness, available with a length over 1075 mm, with E tension member, minimum amount on request

Endless lengths

Type / length	Number of teeth	Type / length	Number of teeth
AT5-E / 225	45	AT5-E / 1900	380
AT5-E / 255	51	AT5-E / 2000	400
AT5-E / 280	56	AT5-E / 2120	424
AT5-E / 305	61	AT5-E / 2240	448
AT5-E / 340	68	AT5-E / 2360	472
AT5-E / 390	78	AT5-E / 2500	500
AT5-E / 420	84	AT5-E / 2650	530
AT5-E / 455	91	AT5-E / 2800	560
AT5-E / 500	100	AT5-E / 3000	600
AT5-E / 545	109	AT5-E / 3150	630
AT5-E / 610	122	AT5-E / 3350	670
AT5-E / 660	132	AT5-E / 3550	710
AT5-E / 720	144	AT5-E / 3750	750
AT5-E / 780	156	AT5-E / 4000	800
AT5-E / 840	168	AT5-E / 4250	850
AT5-E / 855	171	AT5-E / 4500	900
AT5-E / 875	175	AT5-E / 4750	950
AT5-E / 960	192	AT5-E / 5000	1000
AT5-E / 990	198	AT5-E / 5300	1060
AT5-E / 1005	201	AT5-E / 5600	1120
AT5-E / 1020	204	AT5-E / 6000	1200
AT5-E / 1075	215	AT5-E / 6300	1260
AT5-E / 1100	220	AT5-E / 6700	1340
AT5-E / 1215	243	AT5-E / 7100	1420
AT5-E / 1380	276	AT5-E / 7500	1500
AT5-E / 1400	280		
AT5-E / 1500	300		current maximum manufacturing length:
AT5-E / 1600	320		
AT5-E / 1700	340		
AT5-E / 1800	360		
		AT5-E / 15000	3000

Preferred belt width

b [mm]: 10 16 25 32 50 75 100

In-between belt widths are available

Order example

BRECOFLEX®-TIMING BELT 16 AT5 / 720 PAZ-E

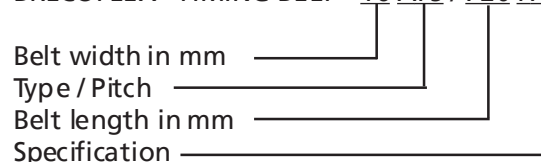

Technical data of the BRECOFLEX® TIMING BELT

AT 5-E, AT 5-DL-E, AT 5-DR-E

Belt width b[cm]

$$b = \frac{F_U}{z_e \cdot F_{U\text{spec}}} \quad F_U [\text{N}]$$

$$b = \frac{100 \cdot M}{z_1 \cdot z_e \cdot M_{\text{spec}}} \quad M [\text{Nm}]$$

$$b = \frac{1000 \cdot P}{z_1 \cdot z_e \cdot P_{\text{spec}}} \quad P [\text{kW}]$$

Drive load bearing characteristics

with given belt width [cm]

$$F_U = F_{U\text{spec}} \cdot z_e \cdot b \quad [\text{N}]$$

$$M = \frac{M_{\text{spec}} \cdot z_1 \cdot z_e \cdot b}{100} \quad [\text{Nm}]$$

$$P = \frac{P_{\text{spec}} \cdot z_1 \cdot z_e \cdot b}{1000} \quad [\text{kW}]$$

intermeshing number of teeth

$$z_{\text{emax}} = 12$$

$$z_e = \frac{z_1}{180} \cdot \arccos \frac{t \cdot (z_2 - z_1)}{2\pi \cdot a}$$

1. Tooth shear strength (specific belt tooth load bearing)

R.p.m. n [rpm]	$F_{U\text{spec}}$ [N/cm]	M_{spec} [Ncm/cm]	P_{spec} [W/cm]	R.p.m. n [rpm]	$F_{U\text{spec}}$ [N/cm]	M_{spec} [Ncm/cm]	P_{spec} [W/cm]
0	35,3	2,810	0,000	2800	19,84	1,579	4,63
20	34,9	2,780	0,058	3000	19,42	1,545	4,85
40	34,5	2,750	0,115	3200	19,01	1,513	5,07
60	34,1	2,720	0,171	3400	18,64	1,483	5,28
80	33,8	2,690	0,225	3600	18,28	1,454	5,48
100	33,5	2,660	0,279	3800	17,93	1,427	5,68
200	32,0	2,550	0,534	4000	17,61	1,401	5,87
300	30,9	2,460	0,771	4500	16,86	1,342	6,32
400	29,8	2,370	0,995	5000	16,18	1,288	6,74
500	29,0	2,300	1,207	5500	15,56	1,239	7,13
600	28,2	2,240	1,409	6000	15,00	1,194	7,50
700	27,5	2,190	1,603	6500	14,48	1,152	7,84
800	26,8	2,140	1,789	7000	13,99	1,113	8,16
900	26,3	2,090	1,969	7500	13,54	1,077	8,46
1000	25,7	2,050	2,140	8000	13,11	1,043	8,74
1100	25,2	2,010	2,310	8500	12,71	1,011	9,00
1200	24,8	1,970	2,480	9000	12,33	0,981	9,24
1300	24,3	1,936	2,640	9500	11,97	0,953	9,47
1400	23,9	1,903	2,790	10000	11,63	0,925	9,69
1500	23,5	1,872	2,940				
1600	23,2	1,843	3,090				
1700	22,8	1,816	3,230				
1800	22,5	1,789	3,370				
1900	22,2	1,764	3,510				
2000	21,9	1,740	3,650				
2200	21,3	1,695	3,910				
2400	20,8	1,654	4,160				
2600	20,3	1,615	4,400				

Rotational speeds over 10000 rpm and/or belt speeds over 80 m/s are in need of a special drive design. Please request for our advice.

2. Tension cord strength (permitted tensile force of the belt F_{adm}), belt weight

Belt width	b	[mm]	10	16	25	32	50	75	100
BRECOFLEX®	F_{adm}	[N]	700	1260	2030	2660	4200	6370	8610
Belt weight	AT 5-E	[kg/m]	0,031	0,052	0,085	0,105	0,164	0,241	0,328
	AT 5-DL-E	[kg/m]	0,040	0,064	0,101	0,130	0,204	0,307	0,410
	AT 5-DR-E	[kg/m]	0,045	0,073	0,115	0,148	0,231	0,348	0,464

3. Flexibility (Minimum numbers of teeth, minimum diameter)

Drive type			BFX AT 5-E	BFX AT 5-DL-E	BFX AT 5-DR-E
without contraflexure	Synchronising pulley	z_{min}	12	20	25
	Tension roller (smooth), running on teeth	d_{min} [mm]	18	20	60
with contraflexure	Synchronising pulley	z_{min}	20	20	25
	Tension roller (smooth), running on the back of the belt	d_{min} [mm]	50	50	60

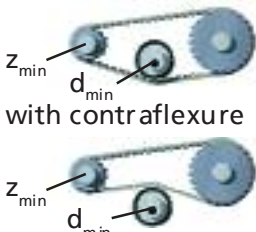

AT high performance timing belt - endless

SYNCHROFLEX® TIMING BELT (SFX)

AT 10 GEN III

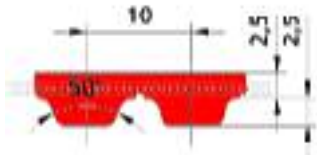

High performance AT profile with metric pitches and trapezoidal teeth

Standard version

- single-sided
- High performance polyurethane in red colour
- Steel cord tension members with high density
- Steel cord tension members in two-filament construction

Product range*

Type GEN III / Length	Number of teeth	Type GEN III / Length	Number of teeth
AT 10 / 500	50	AT 10 / 1280	128
AT 10 / 560	56	AT 10 / 1300	130
AT 10 / 580	58	AT 10 / 1320	132
AT 10 / 600	60	AT 10 / 1350	135
AT 10 / 610	61	AT 10 / 1360	136
AT 10 / 660	66	AT 10 / 1400	140
AT 10 / 700	70	AT 10 / 1480	148
AT 10 / 730	73	AT 10 / 1500	150
AT 10 / 780	78	AT 10 / 1600	160
AT 10 / 800	80	AT 10 / 1700	170
AT 10 / 840	84	AT 10 / 1720	172
AT 10 / 880	88	AT 10 / 1800	180
AT 10 / 890	89	AT 10 / 1860	186
AT 10 / 920	92	AT 10 / 1940	194
AT 10 / 960	96		
AT 10 / 980	98		
AT 10 / 1000	100		
AT 10 / 1010	101		
AT 10 / 1050	105		
AT 10 / 1080	108		
AT 10 / 1100	110		
AT 10 / 1150	115		
AT 10 / 1200	120		
AT 10 / 1210	121		
AT 10 / 1250	125		

Preferred belt width*

b [mm]: 16 25 32 50 75 100 150

*Other dimension upon request.

Order example

SYNCHROFLEX®-TIMING BELT 32 AT10 / 800 GEN III

Belt width in mm _____
 Type / Pitch _____
 Belt length in mm _____
 Specification Generation III _____

Technical data of the SYNCHROFLEX® TIMING BELT

AT 10 GEN III

Belt width b[cm]

$$b = \frac{F_U}{z_e \cdot F_{U\text{spec}}} \quad F_U [\text{N}]$$

$$b = \frac{100 \cdot M}{z_1 \cdot z_e \cdot M_{\text{spec}}} \quad M [\text{Nm}]$$

$$b = \frac{1000 \cdot P}{z_1 \cdot z_e \cdot P_{\text{spec}}} \quad P [\text{kW}]$$

Drive load bearing characteristics

with given belt width [cm]

$$F_U = F_{U\text{spec}} \cdot z_e \cdot b \quad [\text{N}]$$

$$M = \frac{M_{\text{spec}} \cdot z_1 \cdot z_e \cdot b}{100} \quad [\text{Nm}]$$

$$P = \frac{P_{\text{spec}} \cdot z_1 \cdot z_e \cdot b}{1000} \quad [\text{kW}]$$

intermeshing number of teeth

$$z_{e\text{max}} = 16$$

$$z_e = \frac{z_1}{180} \cdot \arccos \frac{t \cdot (z_2 - z_1)}{2\pi \cdot a}$$

1. Tooth shear strength (specific belt tooth load bearing)

R.p.m. n [rpm]	F _{U spec} [N/cm]	M _{spec} [Ncm/cm]	P _{spec} [W/cm]	R.p.m. n [rpm]	F _{U spec} [N/cm]	M _{spec} [Ncm/cm]	P _{spec} [W/cm]
0	91,88	14,63	0,00	2400	47,25	7,51	18,88
20	90,50	14,41	0,30	2600	45,75	7,29	19,83
40	89,25	14,21	0,60	2800	44,38	7,08	20,73
60	88,13	14,01	0,88	3000	43,13	6,88	21,59
80	87,00	13,84	1,16	3200	42,00	6,69	22,40
100	85,88	13,68	1,43	3400	40,88	6,50	23,16
200	81,25	12,94	2,71	3600	39,88	6,34	23,89
300	77,63	12,35	3,88	3800	38,88	6,18	24,59
400	74,38	11,85	4,96	4000	37,88	6,03	25,25
500	71,75	11,41	5,98	4500	35,63	5,68	26,75
600	69,38	11,04	6,94	5000	33,63	5,36	28,13
700	67,13	10,69	7,84	5500	31,88	5,08	29,25
800	65,25	10,39	8,70	6000	30,25	4,81	30,25
900	63,50	10,10	9,53	6500	28,75	4,56	31,13
1000	61,88	9,85	10,31	7000	27,25	4,34	31,88
1100	60,38	9,61	110,8	7500	26,00	4,13	32,50
1200	59,00	9,39	11,80	8000	24,71	3,94	33,00
1300	57,75	9,19	12,50	8500	23,55	3,75	33,38
1400	56,50	8,99	13,18	9000	22,44	3,58	33,63
1500	55,38	8,80	13,84	9500	21,40	3,40	33,88
1600	54,25	8,64	14,46	10000	20,40	3,25	34,00
1700	53,25	8,48	15,08				
1800	52,25	8,31	15,68				
1900	51,25	8,16	16,25				
2000	50,38	8,03	16,80				
2200	48,75	7,75	17,88				

Rotational speeds over 10000 rpm and/or belt speeds over 80 m/s are in need of a special drive design. Please request for our advice.

2. Tension cord strength (permitted tensile force of the belt F_{adm}), belt weight

Belt width	b	[mm]	16	25	32	50	75	100	150
SYNCHROFLEX®	F _{adm}	[N]	3000	5000	6750	10750	16500	22000	33500
Belt weight	AT 10 GEN III	[kg/m]	0,117	0,183	0,234	0,365	0,548	0,730	1,095

3. Flexibility (Minimum numbers of teeth, minimum diameter)

Drive type	SFX AT 10 GEN III		
without contraflexure	Synchronising pulley	z _{min}	15
	Tension roller (smooth), running on teeth	d _{min} [mm]	50
with contraflexure	Synchronising pulley	z _{min}	25
	Tension roller (smooth), running on the back of the belt	d _{min} [mm]	120



AT high performance timing belt - endless

SYNCHROFLEX® TIMING BELT (SFX)

AT 10

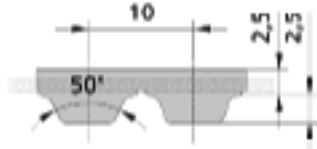

High performance AT profile with metric pitches and trapezoidal teeth.

The technical data refer to standard casting polyurethane and standard steel cord tension members.

Available versions:

- single-sided
- with E tension member for a better flexibility
- with reinforced design
- with Aramid tension member
- Polyurethane special materials upon request
- antistatic, coloured, mechanical reworked

Type / length	Number of teeth	Type / length	Number of teeth
AT 10 / 500	50	AT 10 / 1400	140
AT 10 / 560	56	AT 10 / 1480	148
AT 10 / 580	58	AT 10 / 1500	150
AT 10 / 600	60	AT 10 / 1600	160
AT 10 / 610	61	AT 10 / 1700	170
AT 10 / 660	66	AT 10 / 1720	172
AT 10 / 700	70	AT 10 / 1800	180
AT 10 / 730	73	AT 10 / 1860	186
AT 10 / 780	78	AT 10 / 1940	194
AT 10 / 800	80		
AT 10 / 840	84		
AT 10 / 880	88		
AT 10 / 890	89		
AT 10 / 920	92		
AT 10 / 960	96		
AT 10 / 980	98		
AT 10 / 1000	100		
AT 10 / 1010	101		
AT 10 / 1050	105		
AT 10 / 1080	108		
AT 10 / 1100	110		
AT 10 / 1150	115		
AT 10 / 1200	120		
AT 10 / 1210	121		
AT 10 / 1250	125		
AT 10 / 1280	128		
AT 10 / 1300	130		
AT 10 / 1320	132		
AT 10 / 1350	135		
AT 10 / 1360	136		

Preferred belt width

b [mm]: 16 25 32 50 75 100

In-between widths and larger widths are available

Other dimension upon request

Order examples

SYNCHROFLEX® TIMING BELT 32 AT 10 / 800

Belt width in mm

Type / pitch

Endless length in mm

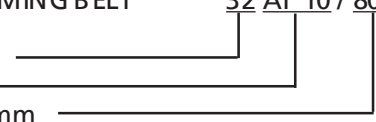

Technical data of the SYNCHROFLEX® TIMING BELT

AT 10

Belt width b[cm]

$$b = \frac{F_U}{z_e \cdot F_{U\text{spec}}} \quad F_U [\text{N}]$$

$$b = \frac{100 \cdot M}{z_1 \cdot z_e \cdot M_{\text{spec}}} \quad M [\text{Nm}]$$

$$b = \frac{1000 \cdot P}{z_1 \cdot z_e \cdot P_{\text{spec}}} \quad P [\text{kW}]$$

Drive load bearing characteristics
with given belt width [cm]

$$F_U = F_{U\text{spec}} \cdot z_e \cdot b \quad [\text{N}]$$

$$M = \frac{M_{\text{spec}} \cdot z_1 \cdot z_e \cdot b}{100} \quad [\text{Nm}]$$

$$P = \frac{P_{\text{spec}} \cdot z_1 \cdot z_e \cdot b}{1000} \quad [\text{kW}]$$

intermeshing number of teeth

$$z_{e\text{max}} = 12$$

$$z_e = \frac{z_1}{180} \cdot \arccos \frac{t \cdot (z_2 - z_1)}{2\pi \cdot a}$$

1. Tooth shear strength (specific belt tooth load bearing)

R.p.m. n [rpm]	F _{U spec} [N/cm]	M _{spec} [Ncm/cm]	P _{spec} [W/cm]	R.p.m. n [rpm]	F _{U spec} [N/cm]	M _{spec} [Ncm/cm]	P _{spec} [W/cm]
0	73,5	11,70	0,000	2800	35,50	5,66	16,58
20	72,4	11,53	0,241	3000	34,50	5,50	17,27
40	71,4	11,37	0,476	3200	33,60	5,35	17,92
60	70,5	11,21	0,705	3400	32,70	5,20	18,53
80	69,6	11,07	0,928	3600	31,90	5,07	19,11
100	68,7	10,94	1,145	3800	31,10	4,94	19,67
200	65,0	10,35	2,170	4000	30,30	4,82	20,20
300	62,1	9,88	3,100	4500	28,50	4,54	21,40
400	59,5	9,48	3,970	5000	26,90	4,29	22,50
500	57,4	9,13	4,780	5500	25,50	4,06	23,40
600	55,5	8,83	5,550	6000	24,20	3,85	24,20
700	53,7	8,55	6,270	6500	23,00	3,65	24,90
800	52,2	8,31	6,960	7000	21,80	3,47	25,50
900	50,8	8,08	7,620	7500	20,80	3,30	26,00
1000	49,5	7,88	8,250	8000	19,77	3,15	26,40
1100	48,3	7,69	8,860	8500	18,84	3,00	26,70
1200	47,2	7,51	9,440	9000	17,95	2,86	26,90
1300	46,2	7,35	10,000	9500	17,12	2,72	27,10
1400	45,2	7,19	10,540	10000	16,32	2,60	27,20
1500	44,3	7,04	11,070				
1600	43,4	6,91	11,570				
1700	42,6	6,78	12,060				
1800	41,8	6,65	12,540				
1900	41,0	6,53	13,000				
2000	40,3	6,42	13,440				
2200	39,0	6,20	14,300				
2400	37,8	6,01	15,100				
2600	36,6	5,83	15,860				

Rotational speeds over 10000 rpm and/or belt speeds over 60 m/s are in need of a special drive design. Please request for our advice.

2. Tension cord strength (permitted tensile force of the belt F_{adm}), belt weight

Belt width	b	[mm]	16	25	32	50	75	100	150
SYNCHROFLEX®	F _{adm}	[N]	2000	3500	4750	7750	12000	16000	24500
Belt weight	AT 10	[kg/m]	0,101	0,158	0,202	0,315	0,473	0,630	0,945

3. Flexibility (Minimum numbers of teeth, minimum diameter)

Drive type	SFX AT 10		
without contraflexure	Synchronising pulley Tension roller (smooth), running on teeth	z _{min} d _{min} [mm]	15 50
with contraflexure	Synchronising pulley Tension roller (smooth), running on the back of the belt	z _{min} d _{min} [mm]	25 120

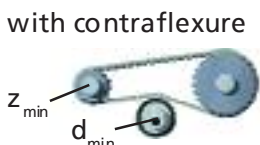

AT high performance timing belt - endless

BRECOFLEX® TIMING BELTS (BFX)

AT 10

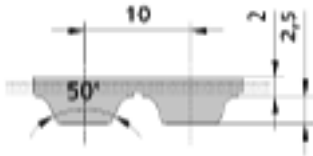

AT 10-DL

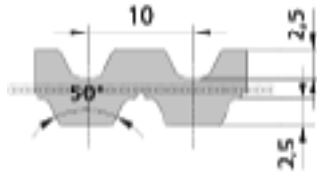

AT 10-DR

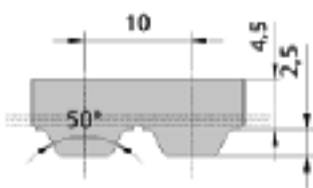

AT 10-T

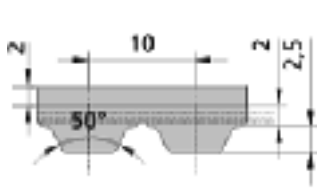

Available endless lengths for AT 10

- Preferred lengths refer to table
- Belt lengths under 1080 mm with nylon tooth facing
- under 1080 mm: maximum manufactured width is 100 mm, further lengths upon request
- over 1080 mm: Any number of teeth available, request minimum purchase amount for intermediate lengths.
- over 20000 mm on request

Available versions:

- **AT 10:** Standard, single-sided
- **E:** with E tension member
- **DL:** Standard, double-sided, available over 1150 mm, available belt width up to $b_{max}=100$, Request minimum purchase amount
- **PAZ:** Nylon tooth facing
- **DL-PAZ:** Nylon on double-sided belts, only inner side can be coated, available belt width up to $b_{max}=100$, minimum amount on request
- **T, T-PAZ:** Transport support, available up to a belt width of $b_{max}=100$, Request minimum purchase amount
- **DR, DR-PAZ:** reinforced back of the belt, through 2.5 mm larger belt thickness, available length over 1080 mm, available belt width up to $b_{max}=100$, Request minimum purchase amount
- *) 150 mm belt width available from 1500 mm to 15000 mm

Endless lengths

Type / length	Number of teeth	Type / length	Number of teeth
AT10 / 400	40	AT10 / 2000	200
AT10 / 500	50	AT10 / 2120	212
AT10 / 530	53	AT10 / 2240	224
AT10 / 560	56	AT10 / 2360	236
AT10 / 610	61	AT10 / 2500	250
AT10 / 630	63	AT10 / 2650	265
AT10 / 660	66	AT10 / 2800	280
AT10 / 700	70	AT10 / 3000	300
AT10 / 720	72	AT10 / 3150	315
AT10 / 780	78	AT10 / 3350	335
AT10 / 800	80	AT10 / 3550	355
AT10 / 810	81	AT10 / 3750	375
AT10 / 840	84	AT10 / 4000	400
AT10 / 850	85	AT10 / 4250	425
AT10 / 880	88	AT10 / 4500	450
AT10 / 890	89	AT10 / 4750	475
AT10 / 920	92	AT10 / 5000	500
AT10 / 960	96	AT10 / 5300	530
AT10 / 970	97	AT10 / 5600	560
AT10 / 980	98	AT10 / 6000	600
AT10 / 1010	101	AT10 / 6300	630
AT10 / 1080	108	AT10 / 6700	670
AT10 / 1150	115	AT10 / 7100	710
AT10 / 1210	121	AT10 / 7500	750
AT10 / 1240	124	AT10 / 8000	800
AT10 / 1250	125	AT10 / 9000	900
AT10 / 1320	132		
AT10 / 1400	140		
AT10 / 1420	142		
AT10 / 1500	150		
AT10 / 1530	153		
AT10 / 1600	160		
AT10 / 1700	170		
AT10 / 1800	180		
AT10 / 1900	190		
			current maximum manufacturing length:
		AT10 / 20000	2000

Preferred belt width

b [mm] 25 32 50 75 100 150*

In-between belt widths are available

Order example

BRECOFLEX®-TIMING BELT 50 AT10 / 2500 DR-PAZ

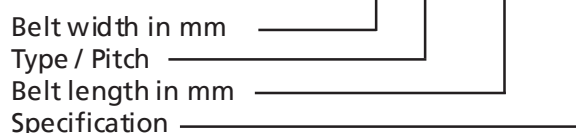

Technical data of the BRECOFLEX® TIMING BELT AT 10, AT 10-DL, AT 10-DR, AT 10-T

Belt width b[cm]

$$b = \frac{F_U}{z_e \cdot F_{U\text{spec}}} \quad F_U [\text{N}]$$

$$b = \frac{100 \cdot M}{z_1 \cdot z_e \cdot M_{\text{spec}}} \quad M [\text{Nm}]$$

$$b = \frac{1000 \cdot P}{z_1 \cdot z_e \cdot P_{\text{spec}}} \quad P [\text{kW}]$$

Drive load bearing characteristics

with given belt width [cm]

$$F_U = F_{U\text{spec}} \cdot z_e \cdot b \quad [\text{N}]$$

$$M = \frac{M_{\text{spec}} \cdot z_1 \cdot z_e \cdot b}{100} \quad [\text{Nm}]$$

$$P = \frac{P_{\text{spec}} \cdot z_1 \cdot z_e \cdot b}{1000} \quad [\text{kW}]$$

intermeshing number of teeth

$$z_{e\text{max}} = 12$$

$$z_e = \frac{z_1}{180} \cdot \arccos \frac{t \cdot (z_2 - z_1)}{2\pi \cdot a}$$

1. Tooth shear strength (specific belt tooth load bearing)



R.p.m. n [rpm]	$F_{U\text{spec}}$ [N/cm]	M_{spec} [Ncm/cm]	P_{spec} [W/cm]	R.p.m. n [rpm]	$F_{U\text{spec}}$ [N/cm]	M_{spec} [Ncm/cm]	P_{spec} [W/cm]
0	73,5	11,70	0,000	2800	35,5	5,66	16,58
20	72,4	11,53	0,241	3000	34,5	5,50	17,27
40	71,4	11,37	0,476	3200	33,6	5,35	17,92
60	70,5	11,21	0,705	3400	32,7	5,20	18,53
80	69,6	11,07	0,928	3600	31,9	5,07	19,11
100	68,7	10,94	1,145	3800	31,1	4,94	19,67
200	65,0	10,35	2,170	4000	30,3	4,82	20,20
300	62,1	9,88	3,100	4500	28,5	4,54	21,40
400	59,5	9,48	3,970	5000	26,9	4,29	22,50
500	57,4	9,13	4,780	5500	25,5	4,06	23,40
600	55,5	8,83	5,550	6000	24,2	3,85	24,20
700	53,7	8,55	6,270	6500	23,0	3,65	24,90
800	52,2	8,31	6,960	7000	21,8	3,47	25,50
900	50,8	8,08	7,620	7500	20,8	3,30	26,00
1000	49,5	7,88	8,250	8000	19,77	3,15	26,40
1100	48,3	7,69	8,860	8500	18,84	3,00	26,70
1200	47,2	7,51	9,440	9000	17,95	2,86	26,90
1300	46,2	7,35	10,000	9500	17,12	2,72	27,10
1400	45,2	7,19	10,540	10000	16,32	2,60	27,20
1500	44,3	7,04	11,070				
1600	43,4	6,91	11,570				
1700	42,6	6,78	12,060				
1800	41,8	6,65	12,540				
1900	41,0	6,53	13,000				
2000	40,3	6,42	13,440				
2200	39,0	6,20	14,300				
2400	37,8	6,01	15,100				
2600	36,6	5,83	15,860				

Rotational speeds over 10000 rpm and/or belt speeds over 60 m/s are in need of a special drive design. Please request for our advice.

2. Tension cord strength (permitted tensile force of the belt F_{adm}), belt weight

Belt width	b	[mm]	25	32	50	75	100	150
BRECOFLEX®	F_{adm}	[N]	3500	4750	7750	12000	16000	24500
Belt weight	AT 10	[kg/m]	0,138	0,180	0,290	0,436	0,581	0,839
	AT 10-DL	[kg/m]	0,184	0,233	0,375	0,566	0,755	-
	AT 10-DR	[kg/m]	0,213	0,275	0,433	0,653	0,871	-
	AT 10-T	[kg/m]	0,198	0,256	0,404	0,609	0,812	-

3. Flexibility (Minimum numbers of teeth, minimum diameter)

Drive type			AT10	AT10-DL	AT10-DR	AT10-T	AT10-E
without contraflexure 	Synchronising pulley	z_{min}	15	25	25	25	12
	Tension roller (smooth), running on teeth	d_{min} [mm]	50	80	80	80	50
with contraflexure 	Synchronising pulley	z_{min}	25	25	25	25	20
	Tension roller (smooth), running on the back of the belt	d_{min} [mm]	120	120	120	120	80

AT high performance timing belt - endless

SYNCHROFLEX® TIMING BELT (SFX)

AT 20

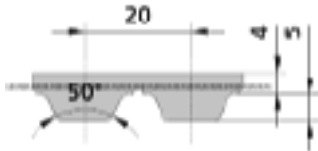

High performance AT profile with metric pitches and trapezoidal teeth.

The technical data refer to standard casting polyurethane and standard steel cord tension members.

Available versions:

- single-sided
- Polyurethane special materials upon request antistatic, coloured, mechanical reworked

Type / Length	Number of teeth	Type / Length	Number of teeth
AT 20 / 1000	50	AT 20 / 1960	98
AT 20 / 1100	55		
AT 20 / 1200	60		
AT 20 / 1260	63		
AT 20 / 1500	75		
AT 20 / 1600	80		
AT 20 / 1700	85		
AT 20 / 1760	88		
AT 20 / 1800	90		
AT 20 / 1900	95		

Preferred belt length mm 32 50 75 100
In-between widths and larger widths are available.

Other dimension upon request.

Order example

SYNCHROFLEX®-TIMING BELT 50 AT20 / 1500

Belt width in mm _____

Type / Pitch _____

Belt length in mm _____

Technical data of the SYNCHROFLEX® TIMING BELT

AT 20

Belt width b[cm]

$$b = \frac{F_U}{z_e \cdot F_{U\text{spec}}} \quad F_U [\text{N}]$$

$$b = \frac{100 \cdot M}{z_1 \cdot z_e \cdot M_{\text{spec}}} \quad M [\text{Nm}]$$

$$b = \frac{1000 \cdot P}{z_1 \cdot z_e \cdot P_{\text{spec}}} \quad P [\text{kW}]$$

Drive load bearing characteristics

with given belt width [cm]

$$F_U = F_{U\text{spec}} \cdot z_e \cdot b \quad [\text{N}]$$

$$M = \frac{M_{\text{spec}} \cdot z_1 \cdot z_e \cdot b}{100} \quad [\text{Nm}]$$

$$P = \frac{P_{\text{spec}} \cdot z_1 \cdot z_e \cdot b}{1000} \quad [\text{kW}]$$

Number of teeth in mesh

$$z_{\text{emax}} = 12$$

$$z_e = \frac{z_1}{180} \cdot \arccos \frac{t \cdot (z_2 - z_1)}{2\pi \cdot a}$$

1. Tooth shear strength (specific belt tooth load bearing)



R.p.m. n [rpm]	F _{Uspec} [N/cm]	M _{spec} [Ncm/cm]	P _{spec} [W/cm]	R.p.m. n [rpm]	F _{Uspec} [N/cm]	M _{spec} [Ncm/cm]	P _{spec} [W/cm]
0	147,0	46,80	0,000	2800	55,5	17,65	51,8
20	144,2	45,90	0,962	3000	53,1	16,90	53,1
40	141,7	45,10	1,889	3200	50,9	16,20	54,3
60	139,3	44,30	2,790	3400	48,8	15,53	55,3
80	137,0	43,60	3,650	3600	46,8	14,91	56,2
100	134,9	42,90	4,500	3800	45,0	14,31	56,9
200	125,8	40,00	8,390	4000	43,2	13,74	57,6
300	118,5	37,70	11,850	4500	39,0	12,43	58,6
400	112,4	35,80	14,990	5000	35,3	11,25	58,8
500	107,2	34,10	17,860	5500	32,0	10,17	60,6
600	102,6	32,70	20,500	6000	28,9	9,19	61,7
700	98,5	31,40	23,000	6500	26,0	8,28	62,4
800	94,8	30,20	25,300				
900	91,5	29,10	27,400				
1000	88,4	28,10	29,500				
1100	85,6	27,20	31,400				
1200	82,9	26,40	33,200				
1300	80,5	25,60	34,900				
1400	78,2	24,90	36,500				
1500	76,0	24,20	38,000				
1600	73,9	23,50	39,400				
1700	72,0	22,90	40,800				
1800	70,1	22,30	42,100				
1900	68,4	21,80	43,300				
2000	66,7	21,20	44,500				
2200	63,6	20,20	46,600				
2400	60,7	19,31	48,500				
2600	58,0	18,45	50,200				

Rotational speeds over 6500 rpm and/or belt speeds over 40 m/s are in need of a special drive design. Please request for our advice.

2. Tension cord strength (permitted tensile force of the belt F_{adm}), belt weight

Belt width	b	[mm]	32	50	75	100	150
SYNCHROFLEX®	F _{adm}	[N]	6750	11250	17550	23850	36450
Belt weight	AT 20	[kg/m]	0,339	0,530	0,795	1,060	1,590

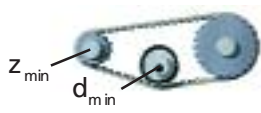
3. Flexibility (Minimum numbers of teeth, minimum diameter)

Drive type	SFX AT20		
without contraflexure	Synchronising pulley	z _{min}	18
	Tension roller (smooth), running on teeth	d _{min} [mm]	120
	with contraflexure	Synchronising pulley	z _{min}
	Tension roller (smooth), running on the back of the belt	d _{min} [mm]	180

AT high performance timing belt - endless

BRECOFLEX® TIMING BELTS (BFX)

AT 20

AT 20-T

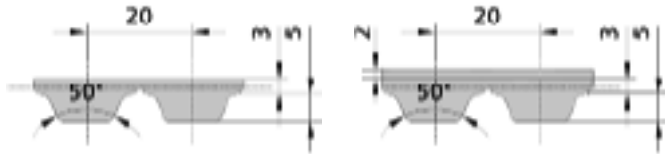

Available endless lengths for AT20

- Preferred lengths refer to table
- under 1,500 mm: further lengths upon request
- over 1,500 mm: Any number of teeth available, request minimum purchase amount for intermediate lengths.
- *) 150 mm belt width available from 1500 mm to 15000 mm
- over 20000 mm: on request

Available versions:

- **AT 20:** Standard, single-sided
- **PAZ:** Nylon tooth facing
- **T, T-PAZ:** Transport support available belt width up to $b_{max}=100$ mm, minimum purchase amount on request

Endless lengths

Type / Length	Number of teeth	Type / Length	Number of teeth
AT 20 / 1500	75	AT 20 / 4760	238
AT 20 / 1600	80	AT 20 / 5000	250
AT 20 / 1700	85	AT 20 / 5300	265
AT 20 / 1800	90	AT 20 / 5600	280
AT 20 / 1900	95	AT 20 / 6000	300
AT 20 / 2000	100	AT 20 / 6300	315
AT 20 / 2120	106	AT 20 / 6700	335
AT 20 / 2240	112	AT 20 / 7100	355
AT 20 / 2360	118	AT 20 / 7500	375
AT 20 / 2500	125	AT 20 / 8000	400
AT 20 / 2660	133	AT 20 / 8500	425
AT 20 / 2800	140	AT 20 / 9000	450
AT 20 / 3000	150		
AT 20 / 3160	158		
AT 20 / 3360	168		
AT 20 / 3560	178		
AT 20 / 3760	188		
AT 20 / 4000	200		
AT 20 / 4260	213		
AT 20 / 4500	225		

current maximum manufacturing length:
AT 20 / 20000 1000

Preferred belt length mm 32 50 75 100 150*)
In-between belt widths are available

Order example

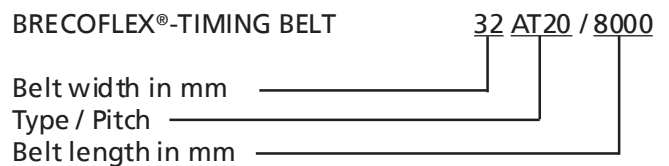

Technical data of the BRECOFLEX® TIMING BELT

AT 20, AT 20-T

Belt width b[cm]

$$b = \frac{F_U}{z_e \cdot F_{Uspec}} \quad F_U [\text{N}]$$

$$b = \frac{100 \cdot M}{z_1 \cdot z_e \cdot M_{spec}} \quad M [\text{Nm}]$$

$$b = \frac{1000 \cdot P}{z_1 \cdot z_e \cdot P_{spec}} \quad P [\text{kW}]$$

Drive load bearing characteristics

with given belt width [cm] is

$$F_U = F_{Uspec} \cdot z_e \cdot b \quad [\text{N}]$$

$$M = \frac{M_{spec} \cdot z_1 \cdot z_e \cdot b}{100} \quad [\text{Nm}]$$

$$P = \frac{P_{spec} \cdot z_1 \cdot z_e \cdot b}{1000} \quad [\text{kW}]$$

intermeshing number of teeth

$$z_{e\max} = 12$$

$$z_e = \frac{z_1}{180} \cdot \arccos \frac{t \cdot (z_2 - z_1)}{2\pi \cdot a}$$

1. Tooth shear strength (specific belt tooth load bearing)

R.p.m. n [rpm]	F_{Uspec} [N/cm]	M_{spec} [Ncm/cm]	P_{spec} [W/cm]	R.p.m. n [rpm]	F_{Uspec} [N/cm]	M_{spec} [Ncm/cm]	P_{spec} [W/cm]
0	147,0	46,80	0,000	2800	55,5	17,65	51,8
20	144,2	45,90	0,962	3000	53,1	16,90	53,1
40	141,7	45,10	1,889	3200	50,9	16,20	54,3
60	139,3	44,30	2,790	3400	48,8	15,53	55,3
80	137,0	43,60	3,650	3600	46,8	14,91	56,2
100	134,9	42,90	4,500	3800	45,0	14,31	56,9
200	125,8	40,00	8,390	4000	43,2	13,74	57,6
300	118,5	37,70	11,850	4500	39,0	12,43	58,6
400	112,4	35,80	14,990	5000	35,3	11,25	58,8
500	107,2	34,10	17,860	5500	32,0	10,17	60,6
600	102,6	32,70	20,500	6000	28,9	9,19	61,7
700	98,5	31,40	23,000	6500	26,0	8,28	62,4
800	94,8	30,20	25,300				
900	91,5	29,10	27,400				
1000	88,4	28,10	29,500				
1100	85,6	27,20	31,400				
1200	82,9	26,40	33,200				
1300	80,5	25,60	34,900				
1400	78,2	24,90	36,500				
1500	76,0	24,20	38,000				
1600	73,9	23,50	39,400				
1700	72,0	22,90	40,800				
1800	70,1	22,30	42,100				
1900	68,4	21,80	43,300				
2000	66,7	21,20	44,500				
2200	63,6	20,20	46,600				
2400	60,7	19,31	48,500				
2600	58,0	18,45	50,200				

Rotational speeds over 6500 rpm and/or belt speeds over 40 m/s are in need of a special drive design. Please request for our advice.

2. Tension cord strength (permitted tensile force of the belt F_{adm}), belt weight

Belt width	b	[mm]	32	50	75	100	150
BRECOFLEX®	F_{adm}	[N]	6000	10000	15600	21200	32400
Belt weight	AT 20	[kg/m]	0,307	0,480	0,720	0,960	1,423
Belt weight	AT 20-T	[kg/m]	0,372	0,588	0,888	1,187	-

3. Flexibility (Minimum numbers of teeth, minimum diameter)

Drive type		BFX AT20	BFX AT20-T
without contraflexure	Synchronising pulley	z_{min} 18	25
	Tension roller (smooth), running on teeth	d_{min} [mm] 120	120
with contraflexure	Synchronising pulley	z_{min} 25	25
	Tension roller (smooth), running on the back of the belt	d_{min} [mm] 180	180

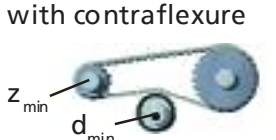
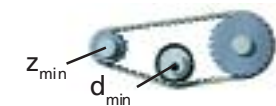

ATP high performance timing belt - endless

SYNCHROFLEX® TIMING BELT (SFX)

ATP 10 GEN III

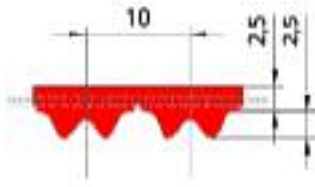

High performance ATP profile with metric pitch and optimised meshing with a double support of the tooth head.

Standard version:

- single-sided
- High performance polyurethane in red colour
- Steel cord tension members with high density
- Steel cord tension members in two-filament construction

Product range*

Type GEN III / Length	Number of teeth	Type GEN III / Length	Number of teeth
ATP 10 / 630	63	ATP 10 / 1280	128
ATP 10 / 660	66	ATP 10 / 1400	140
ATP 10 / 700	70	ATP 10 / 1650	165
ATP 10 / 780	78	ATP 10 / 1800	180
ATP 10 / 840	84	ATP 10 / 1760**	176
ATP 10 / 890	89		
ATP 10 / 920	92		
ATP 10 / 1010	101		
ATP 10 / 1080	108		
ATP 10 / 1150	115		

Preferred belt width

b [mm]: 16 25 32 50 75 100 150

*Other dimension upon request.

** in preparation

Order example

SYNCHROFLEX®-TIMING BELT 32 ATP10 / 780 GEN III

Belt width in mm _____
 Type / Pitch _____
 Belt length in mm _____
 Specification Generation III _____

Technical data of the SYNCHROFLEX® TIMING BELT

ATP 10 GEN III

Belt width b[cm]

$$b = \frac{F_U}{z_e \cdot F_{U\text{spec}}} \quad F_U [\text{N}]$$

$$b = \frac{100 \cdot M}{z_1 \cdot z_e \cdot M_{\text{spec}}} \quad M [\text{Nm}]$$

$$b = \frac{1000 \cdot P}{z_1 \cdot z_e \cdot P_{\text{spec}}} \quad P [\text{kW}]$$

Drive load bearing characteristics

with given belt width [cm]
 $F_U = F_{U\text{spec}} \cdot z_e \cdot b \quad [\text{N}]$

$$M = \frac{M_{\text{spec}} \cdot z_1 \cdot z_e \cdot b}{100} \quad [\text{Nm}]$$

$$P = \frac{P_{\text{spec}} \cdot z_1 \cdot z_e \cdot b}{1000} \quad [\text{kW}]$$

intermeshing number of teeth

$$z_{e\text{max}} = 16$$

$$z_e = \frac{z_1}{180} \cdot \arccos \frac{t \cdot (z_2 - z_1)}{2\pi \cdot a}$$

1. Tooth shear strength (specific belt tooth load bearing)

R.p.m. n [rpm]	F _{U spec} [N/cm]	M _{spec} [Ncm/cm]	P _{spec} [W/cm]	R.p.m. n [rpm]	F _{U spec} [N/cm]	M _{spec} [Ncm/cm]	P _{spec} [W/cm]
0	105,050	16,713	0,000	2400	53,957	8,584	21,575
20	103,508	16,468	0,345	2600	52,318	8,324	22,663
40	102,064	16,238	0,680	2800	50,790	8,081	23,694
60	100,706	16,023	1,007	3000	49,358	7,853	24,671
80	99,424	15,818	1,326	3200	48,010	7,638	25,597
100	98,210	15,626	1,637	3400	46,737	7,436	26,476
150	95,432	15,183	2,385	3600	45,532	7,245	27,310
200	92,956	14,790	3,098	3800	44,387	7,062	28,102
300	88,706	14,110	4,433	4000	43,297	6,888	28,855
400	85,093	13,538	4,433	4500	40,780	6,488	30,575
500	81,989	13,045	6,830	5000	38,513	6,127	32,084
600	79,257	12,609	7,923	5500	36,452	5,799	33,403
700	76,817	12,222	8,985	6000	34,561	5,499	34,549
800	74,614	11,871	9,945	6500	32,815	5,221	35,538
900	72,604	11,551	10,887	7000	31,194	4,963	36,380
1000	70,758	11,257	11,789	7500	29,679	4,722	37,087
1100	69,049	10,986	12,654	8000	28,260	4,496	37,666
1200	67,461	10,733	13,487	8500	26,923	4,283	38,128
1300	65,975	10,496	14,290	9000	25,661	4,082	38,477
1400	64,580	10,275	15,063	9500	24,464	3,892	38,721
1500	63,265	10,065	15,811	10000	23,328	3,711	38,865
1600	62,022	9,868	16,534				
1700	60,844	9,680	17,234				
1800	59,723	9,502	17,911				
1900	58,655	9,332	18,568				
2000	57,636	9,170	19,205				
2200	55,722	8,865	20,425				

Rotational speeds over 10000 rpm and/or belt speeds over 80 m/s are in need of a special drive design. Please request for our advice.

2. Tension cord strength (permitted tensile force of the belt F_{adm}), belt weight

Belt width	b	[mm]	16	25	32	50	75	100	150
SYNCHROFLEX®	F _{adm}	[N]	3000	5000	6750	10750	16500	22000	33500
Belt weight	ATP10 GEN III	[kg/m]	0,109	0,170	0,218	0,340	0,510	0,680	1,020

3. Flexibility (Minimum numbers of teeth, minimum diameter)

Drive type	SFX ATP 10 GEN III		
without contraflexure	Synchronising pulley	z _{min}	15
	Tension roller (smooth), running on teeth	d _{min} [mm]	50
with contraflexure	Synchronising pulley	z _{min}	25
	Tension roller (smooth), running on the back of the belt	d _{min} [mm]	120

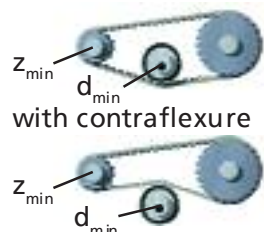

ATP high performance timing belt - endless

SYNCHROFLEX[®] TIMING BELT (SFX)

ATP 10

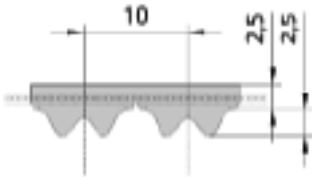

High performance ATP profile with metric pitch and optimised meshing with a double support of the tooth head.

Available versions:

- single-sided
- with E tension member for a better flexibility
- with reinforced tension member design
- Polyurethane special materials upon request (Standard: DADU 9311, colour: yellow)
- antistatic, coloured, mechanical reworked

Product range*

Type / length	Number of teeth	Type / length	Number of teeth
ATP 10 / 630	63	ATP 10 / 1280	128
ATP 10 / 660	66	ATP 10 / 1400	140
ATP 10 / 700	70	ATP 10 / 1650	165
ATP 10 / 780	78	ATP 10 / 1760**	176
ATP 10 / 840	84	ATP 10 / 1800	180
ATP 10 / 890	89		
ATP 10 / 920	92		
ATP 10 / 1010	101		
ATP 10 / 1080	108		
ATP 10 / 1150	115		

Preferred belt width

b [mm]: 16 25 32 50 75 100

In-between widths and larger widths are available

* Other dimension upon request.

** in preparation

Order example

SYNCHROFLEX[®]-TIMING BELT 32 ATP10 / 780

Belt width in mm _____
Type / Pitch _____
Belt length in mm _____

Technical data of the SYNCHROFLEX® TIMING BELT

ATP 10

Belt width b[cm]

$$b = \frac{F_U}{z_e \cdot F_{U\text{spec}}}$$

F_U [N]

$$b = \frac{100 \cdot M}{z_1 \cdot z_e \cdot M_{\text{spec}}}$$

M [Nm]

$$b = \frac{1000 \cdot P}{z_1 \cdot z_e \cdot P_{\text{spec}}}$$

P [kW]

Drive load bearing characteristics with given belt width [cm]

$$F_U = F_{U\text{spec}} \cdot z_e \cdot b$$

[N]

$$M = \frac{M_{\text{spec}} \cdot z_1 \cdot z_e \cdot b}{100}$$

[Nm]

$$P = \frac{P_{\text{spec}} \cdot z_1 \cdot z_e \cdot b}{1000}$$

[kW]

intermeshing number of teeth

$$z_{e\text{max}} = 12$$

$$z_e = \frac{z_1}{180} \cdot \arccos \frac{t \cdot (z_2 - z_1)}{2\pi \cdot a}$$

1. Tooth shear strength (specific belt tooth load bearing)



R.p.m. n [rpm]	$F_{U\text{spec}}$ [N/cm]	M_{spec} [Ncm/cm]	P_{spec} [W/cm]	R.p.m. n [rpm]	$F_{U\text{spec}}$ [N/cm]	M_{spec} [Ncm/cm]	P_{spec} [W/cm]
0	95,500	15,199	0,000	2200	50,656	8,062	18,572
20	94,098	14,976	0,314	2400	49,052	7,807	19,619
40	92,785	14,767	0,619	2600	47,562	7,570	20,609
60	91,551	14,571	0,915	2800	46,173	7,349	21,546
80	90,385	14,385	1,205	2880	45,642	7,264	21,907
100	89,282	14,210	1,488	3000	44,871	7,141	22,434
150	86,756	13,808	2,169	3200	43,645	6,946	23,276
200	84,505	13,449	2,817	3400	42,488	6,762	24,075
300	80,642	12,835	4,032	3600	41,393	6,588	24,834
400	77,357	12,312	5,157	3800	40,352	6,422	25,554
500	74,535	11,863	6,211	4000	39,361	6,264	26,239
600	72,052	11,467	7,205	4500	37,073	5,900	27,803
700	69,834	11,114	8,147	5000	35,012	5,572	29,175
730	69,212	11,015	8,420	5500	33,138	5,274	30,374
800	67,831	10,796	9,043	6000	31,419	5,000	31,417
900	66,004	10,505	9,900	6500	29,832	4,748	32,316
1000	64,325	10,238	10,720	7000	28,358	4,513	33,082
1100	62,772	9,990	11,507	7500	26,981	4,294	33,724
1200	61,328	9,761	12,265	8000	25,691	4,089	34,252
1300	59,977	9,546	12,994	8500	24,475	3,895	34,670
1400	58,709	9,344	13,698	9000	23,328	3,713	34,989
1460	57,984	9,228	14,108	9500	22,240	3,540	35,211
1500	57,514	9,154	14,377	10000	21,207	3,375	35,342
1600	56,348	8,968	15,025				
1700	55,313	8,803	15,671				
1800	54,294	8,641	16,287				
1900	53,323	8,487	16,884				
2000	52,396	8,339	17,464				

Rotational speeds over 10000 rpm and/or belt speeds over 40 m/s are in need of a special drive design. Please request for our advice.

2. Tension cord strength (permitted tensile force of the belt F_{adm}), belt weight

Belt width	b	[mm]	16	25	32	50	75	100	150
SYNCHROFLEX®	F_{adm}	[N]	2000	3500	4750	7750	12000	16000	24500
Belt weight	ATP 10	[kg/m]	0,096	0,15	0,192	0,300	0,450	0,600	0,900

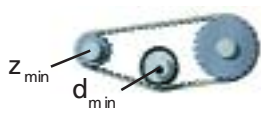
3. Flexibility (Minimum numbers of teeth, minimum diameter)

Drive type	SFX ATP 10		
without contraflexure	Synchronising pulley	z_{min}	15
	Tension roller (smooth), running on teeth	d_{min} [mm]	50
with contraflexure	Synchronising pulley	z_{min}	25
	Tension roller (smooth), running on the back of the belt	d_{min} [mm]	120

ATP high performance timing belt - endless

BRECOFLEX® TIMING BELTS (BFX)

ATP 10

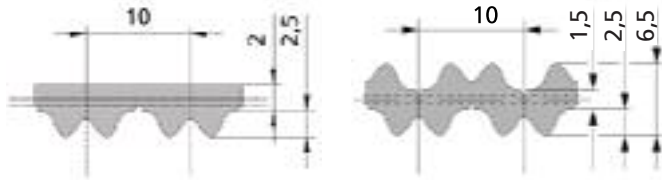

Available endless lengths for ATP 10

- Preferred lengths refer to table
- under 1500 mm: not available
- over 1500 mm: Any number of teeth available, request minimum purchase amount for intermediate lengths.
- over 12000 mm on request

Available versions:

- **ATP 10:** Standard, single-sided
- **DL:** Standard, double-sided

Endless lengths

Type / length	Number of teeth	Type / length	Number of teeth
ATP 10 / 1500	150	ATP 10 / 3750	375
ATP 10 / 1600	160	ATP 10 / 4000	400
ATP 10 / 1700	170	ATP 10 / 4250	425
ATP 10 / 1900	190	ATP 10 / 4500	450
ATP 10 / 2000	200	ATP 10 / 4750	475
ATP 10 / 2120	212	ATP 10 / 5000	500
ATP 10 / 2240	224	ATP 10 / 5300	530
ATP 10 / 2360	236	ATP 10 / 5600	560
ATP 10 / 2500	250	ATP 10 / 6000	600
ATP 10 / 2650	265	ATP 10 / 6300	630
ATP 10 / 2800	280		
ATP 10 / 3000	300		
ATP 10 / 3150	315		
ATP 10 / 3350	335		
ATP 10 / 3550	355		
		current maximum manufacturing length:	
		ATP 10 / 12000	1200

Preferred belt width

b [mm]: 16 25 32 50 75 100

In-between belt widths are available

Order example

BRECOFLEX®-TIMING BELT 32 ATP10 / 1900

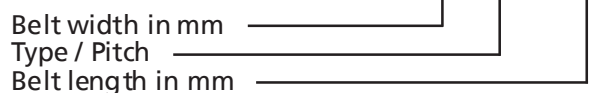

Technical data of the BRECOFLEX® TIMING BELT

ATP 10

Belt width b[cm]

$$b = \frac{F_U}{z_e \cdot F_{U\text{spec}}} \quad F_U [\text{N}]$$

$$b = \frac{100 \cdot M}{z_1 \cdot z_e \cdot M_{\text{spec}}} \quad M [\text{Nm}]$$

$$b = \frac{1000 \cdot P}{z_1 \cdot z_e \cdot P_{\text{spec}}} \quad P [\text{kW}]$$

Drive load bearing characteristics
with given belt width [cm]

$$F_U = F_{U\text{spec}} \cdot z_e \cdot b \quad [\text{N}]$$

$$M = \frac{M_{\text{spec}} \cdot z_1 \cdot z_e \cdot b}{100} \quad [\text{Nm}]$$

$$P = \frac{P_{\text{spec}} \cdot z_1 \cdot z_e \cdot b}{1000} \quad [\text{kW}]$$

intermeshing number of teeth

$$z_{e\text{max}} = 12$$

$$z_e = \frac{z_1}{180} \cdot \arccos \frac{t \cdot (z_2 - z_1)}{2\pi \cdot a}$$

1. Tooth shear strength (specific belt tooth load bearing)

R.p.m. n [rpm]	$F_{U\text{spec}}$ [N/cm]	M_{spec} [Ncm/cm]	P_{spec} [W/cm]	R.p.m. n [rpm]	$F_{U\text{spec}}$ [N/cm]	M_{spec} [Ncm/cm]	P_{spec} [W/cm]
0	95,500	15,199	0,000	2200	50,656	8,062	18,572
20	94,098	14,976	0,314	2400	49,052	7,807	19,619
40	92,785	14,767	0,619	2600	47,562	7,570	20,609
60	91,551	14,571	0,915	2800	46,173	7,349	21,546
80	90,385	14,385	1,205	2880	45,642	7,264	21,907
100	89,282	14,210	1,488	3000	44,871	7,141	22,434
150	86,756	13,808	2,169	3200	43,645	6,946	23,276
200	84,505	13,449	2,817	3400	42,488	6,762	24,075
300	80,642	12,835	4,032	3600	41,393	6,588	24,834
400	77,357	12,312	5,157	3800	40,352	6,422	25,554
500	74,535	11,863	6,211	4000	39,361	6,264	26,239
600	72,052	11,467	7,205	4500	37,073	5,900	27,803
700	69,834	11,114	8,147	5000	35,012	5,572	29,175
730	69,212	11,015	8,420	5500	33,138	5,274	30,374
800	67,831	10,796	9,043	6000	31,419	5,000	31,417
900	66,004	10,505	9,900	6500	29,832	4,748	32,316
1000	64,325	10,238	10,720	7000	28,358	4,513	33,082
1100	62,772	9,990	11,507	7500	26,981	4,294	33,724
1200	61,328	9,761	12,265	8000	25,691	4,089	34,252
1300	59,977	9,546	12,994	8500	24,475	3,895	34,670
1400	58,709	9,344	13,698	9000	23,328	3,713	34,989
1460	57,984	9,228	14,108	9500	22,240	3,540	35,211
1500	57,514	9,154	14,377	10000	21,207	3,375	35,342
1600	56,348	8,968	15,025	Rotational speeds over 10000 rpm and/or belt speeds over 40 m/s are in need of a special drive design. Please request for our advice.			
1700	55,313	8,803	15,671				
1800	54,294	8,641	16,287				
1900	53,323	8,487	16,884				
2000	52,396	8,339	17,464				

2. Tension cord strength (permitted tensile force of the belt F_{adm}), belt weight

Belt width	b	[mm]	16	25	32	50	75	100
BRECOFLEX®	F_{adm}	[N]	2000	3500	4750	7750	12000	16000
Belt weight	ATP 10	[kg/m]	0,096	0,150	0,192	0,300	0,450	0,600
	ATP 10-DL	[kg/m]	0,097	0,154	0,200	0,316	0,477	0,636

3. Flexibility (Minimum numbers of teeth, minimum diameter)

Drive type			BFX ATP 10	BFX ATP 10-DL
without contraflexure	Synchronising pulley	z_{min}	15	25
	Tension roller (smooth), running on teeth	d_{min} [mm]	50	80
with contraflexure	Synchronising pulley	z_{min}	25	25
	Tension roller (smooth), running on the back of the belt	d_{min} [mm]	120	120

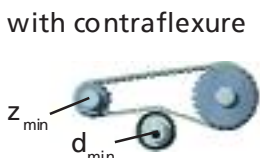
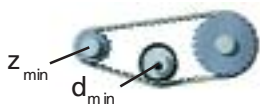

ATP high performance timing belt - endless

SYNCHROFLEX® TIMING BELT (SFX)

ATP 15

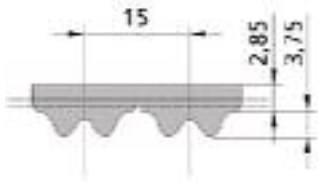

Type / Length*	Number of teeth	Type / Length	Number of teeth
ATP 15 / 990**	66	ATP 15 / 1560	104
ATP 15 / 1125	75		
ATP 15 / 1185	79		
ATP 15 / 1260	84		
ATP 15 / 1395**	93		

High performance ATP profile with metric pitch and optimised meshing with a double support of the tooth head.

Preferred belt width

b [mm]: 25 32 50 75 100 150

Available versions:

- single-sided
- with E tension member for a better flexibility
- with reinforced tension member design
- Polyurethane special materials upon request (Standard: DADU 9311, colour: yellow)
- antistatic, coloured, mechanical reworked

In-between belt widths are available

* Other dimensions upon request

** dimensions in preparation

Order example

SYNCHROFLEX®-TIMING BELT 32 ATP15 / 1260

Belt width in mm _____
 Type / Pitch _____
 Belt length in mm _____

Technical data of the SYNCHROFLEX® TIMING BELT

ATP 15

Belt width b[cm]

$$b = \frac{F_U}{z_e \cdot F_{U\text{spec}}} \quad F_U[\text{N}]$$

$$b = \frac{100 \cdot M}{z_1 \cdot z_e \cdot M_{\text{spec}}} \quad M[\text{Nm}]$$

$$b = \frac{1000 \cdot P}{z_1 \cdot z_e \cdot P_{\text{spec}}} \quad P[\text{kW}]$$

Drive load bearing characteristics
with given belt width [cm]

$$F_U = F_{U\text{spec}} \cdot z_e \cdot b \quad [\text{N}]$$

$$M = \frac{M_{\text{spec}} \cdot z_1 \cdot z_e \cdot b}{100} \quad [\text{Nm}]$$

$$P = \frac{P_{\text{spec}} \cdot z_1 \cdot z_e \cdot b}{1000} \quad [\text{kW}]$$

intermeshing number of teeth

$$z_{\text{emax}} = 12$$

$$z_e = \frac{z_1}{180} \cdot \arccos \frac{t \cdot (z_2 - z_1)}{2\pi \cdot a}$$

1. Tooth shear strength (specific belt tooth load bearing)



R.p.m. n [rpm]	F _{U spec} [N/cm]	M _{spec} [Ncm/cm]	P _{spec} [W/cm]	R.p.m. n [rpm]	F _{U spec} [N/cm]	M _{spec} [Ncm/cm]	P _{spec} [W/cm]
0	143,325	34,216	0,000	2200	69,141	16,506	38,027
20	140,945	33,648	0,705	2400	66,523	15,881	39,914
40	138,722	33,117	1,387	2600	64,094	15,301	41,661
60	136,637	32,620	2,050	2800	61,828	14,760	43,280
80	134,674	32,151	2,693	3000	59,706	14,254	44,779
100	132,818	31,708	3,320	3200	57,709	13,777	46,167
150	128,584	30,697	4,822	3400	55,824	13,327	47,451
200	124,832	29,799	6,241	3600	54,040	12,901	48636
300	118,367	28,258	8,877	3800	52,345	12,496	49,727
400	112,952	26,965	11,295	4000	50,731	12,111	50,731
500	108,288	25,852	13,536	4500	47,006	11,222	52,881
600	104,193	24,874	15,629	5000	43,652	10,421	54,565
700	100,542	24,003	17,595	5500	40,602	9,693	55,828
800	97,249	23,216	19,450	6000	37,806	9,026	56,709
900	94,249	22,500	21,206	6500	35,225	8,409	57,240
1000	91,495	21,843	22,874	7000	32,827	7,837	57,447
1100	88,949	21,235	24,461	7500	30,589	7,303	57,354
1200	86,583	20,670	25,975	8000	28,490	6,802	56,980
1300	84,372	20,142	27,421	8500	26,515	6,330	56,344
1400	82,297	19,647	28,804	9000	24,649	5,884	55,460
1500	80,343	19,180	30,128	9500	22,881	5,462	54,342
1600	78,495	18,739	31,398	10000	21,201	5,061	53,003
1700	76,745	18,321	32,616				
1800	75,080	17,924	33,786				
1900	73,494	17,545	34,910				
2000	71,980	17,184	35,990				

Rotational speeds over 10000 rpm and/or belt speeds over 40 m/s are in need of a special drive design. Please request for our advice.

2. Tension cord strength (permitted tensile force of the belt F_{adm}), belt weight

Belt width	b	[mm]	25	32	50	75	100	150
SYNCHROFLEX®	F _{adm}	[N]	4950	6750	11250	17550	23850	36450
Belt weight	ATP 15	[kg/m]	0,200	0,256	0,400	0,600	0,800	1,200

3. Flexibility (Minimum numbers of teeth, minimum diameter)

Drive type	SFX ATP 15		
without contraflexure	Synchronising pulley	z _{min}	20
	Tension roller (smooth), running on teeth	d _{min} [mm]	100
with contraflexure	Synchronising pulley	z _{min}	30
	Tension roller (smooth), running on the back of the belt	d _{min} [mm]	160

ATP high performance timing belt - endless

BRECOFLEX® TIMING BELTS (BFX)

ATP 15

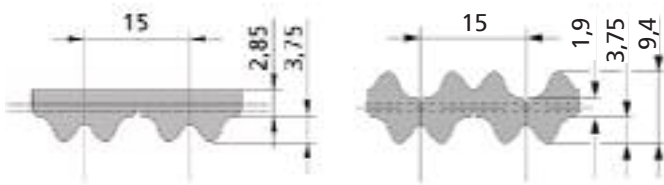

Endless lengths

Type / length	Number of teeth	Type / length	Number of teeth
ATP 15 / 1740	116	ATP 15 / 4875	325
ATP 15 / 1965	131	ATP 15 / 5250	350
ATP 15 / 2100	140	ATP 15 / 5625	375
ATP 15 / 2250	150	ATP 15 / 6000	400
ATP 15 / 2385	159		
ATP 15 / 2520	168	current maximum manufacturing length:	
ATP 15 / 2670	178		
ATP 15 / 2805	187		
ATP 15 / 3000	200	ATP 15 / 12000	800
ATP 15 / 3225	215		
ATP 15 / 3450	230		
ATP 15 / 3675	245		
ATP 15 / 3900	260		
ATP 15 / 4125	275		
ATP 15 / 4500	300		

Available endless lengths for ATP 15

- Preferred lengths refer to table
- under 1740 mm: not available
- over 1740 mm: Any number of teeth available, request minimum purchase amount for intermediate lengths.
- max. manufacturing width: 150 mm
- over 12000 mm on request

Available versions:

- **ATP 15:** Standard, single-sided
- **DL:** Standard, double-sided

Preferred belt width

b [mm]: 25 32 50 75 100 150

In-between belt widths are available

Order example

BRECOFLEX®-TIMING BELT 50 ATP15 / 3900

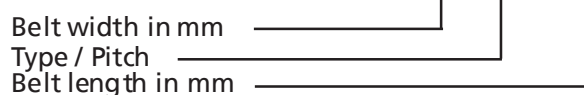

Technical data of the BRECOFLEX® TIMING BELT

ATP 15

Belt width b[cm]

$$b = \frac{F_U}{z_e \cdot F_{U\text{spec}}}$$

F_U [N]

$$b = \frac{100 \cdot M}{z_1 \cdot z_e \cdot M_{\text{spec}}}$$

M [Nm]

$$b = \frac{1000 \cdot P}{z_1 \cdot z_e \cdot P_{\text{spec}}}$$

P [kW]

Drive load bearing characteristics with given belt width [cm]

$$F_U = F_{U\text{spec}} \cdot z_e \cdot b \quad [\text{N}]$$

$$M = \frac{M_{\text{spec}} \cdot z_1 \cdot z_e \cdot b}{100} \quad [\text{Nm}]$$

$$P = \frac{P_{\text{spec}} \cdot z_1 \cdot z_e \cdot b}{1000} \quad [\text{kW}]$$

intermeshing number of teeth

$$z_{e\text{max}} = 12$$

$$z_e = \frac{z_1}{180} \cdot \arccos \frac{t \cdot (z_2 - z_1)}{2\pi \cdot a}$$

1. Tooth shear strength (specific belt tooth load bearing)

R.p.m. n [rpm]	$F_{U\text{spec}}$ [N/cm]	M_{spec} [Ncm/cm]	P_{spec} [W/cm]	R.p.m. n [rpm]	$F_{U\text{spec}}$ [N/cm]	M_{spec} [Ncm/cm]	P_{spec} [W/cm]
0	143,325	34,216	0,000	2400	66,523	15,881	39,914
20	140,945	33,648	0,705	2600	64,094	15,301	41,661
40	138,722	33,117	1,387	2800	61,828	14,760	43,280
60	136,637	32,620	2,050	3000	59,706	14,254	44,779
80	134,674	32,151	2,693	3200	57,709	13,777	46,167
100	132,818	31,708	3,320	3400	55,824	13,327	47,451
150	128,584	30,697	4,822	3600	54,040	12,901	48,636
200	124,832	29,799	6,241	3800	52,345	12,496	49,727
300	118,367	28,258	8,877	4000	50,731	12,111	50,731
400	112,952	26,965	11,295	4500	47,006	11,222	52,881
500	108,288	25,852	13,536	5000	43,652	10,421	54,565
600	104,193	24,874	15,629	5500	40,602	9,693	55,828
700	100,542	24,003	17,595	6000	37,806	9,026	56,709
800	97,249	23,216	19,450	6500	35,225	8,409	57,240
900	94,249	22,500	21,206	7000	32,827	7,837	57,447
1000	91,495	21,843	22,874	7500	30,589	7,303	57,354
1100	88,949	21,235	24,461	8000	28,490	6,802	56,980
1200	86,583	20,670	25,975	8500	26,515	6,330	56,344
1300	84,372	20,142	27,421	9000	24,649	5,884	55,460
1400	82,297	19,647	28,804	9500	22,881	5,462	54,342
1500	80,343	19,180	30,128	10000	21,201	5,061	53,003
1600	78,495	18,739	31,398				
1700	76,745	18,321	32,616				
1800	75,080	17,924	33,786				
1900	73,494	17,545	34,910				
2000	71,980	17,184	35,990				
2200	69,141	16,506	38,027				

Rotational speeds over 10000 rpm and/or belt speeds over 40 m/s are in need of a special drive design. Please request for our advice.

2. Tension cord strength (permitted tensile force of the belt F_{adm}), belt weight

Belt width	b	[mm]	25	32	50	75	100	150
BRECOFLEX®	F_{adm}	[N]	4950	6750	11250	17550	23850	36450
Belt weight	ATP 15	[kg/m]	0,200	0,256	0,400	0,600	0,800	1,200
	ATP 15-DL	[kg/m]	0,210	0,272	0,432	0,654	0,876	-

3. Flexibility (Minimum numbers of teeth, minimum diameter)

Drive type		BFX ATP 15	BFX ATP 15-DL
without contraflexure	Synchronising pulley Tension roller (smooth), running on teeth	z_{min} 20 d_{min} [mm] 100	25 120
with contraflexure	Synchronising pulley Tension roller (smooth), running on the back of the belt	z_{min} 30 d_{min} [mm] 160	30 160

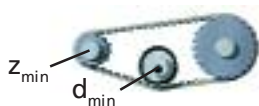

Self-guiding timing belts - endless

BRECOFLEX® TIMING BELT (BFX) with curved teeth

BAT 10

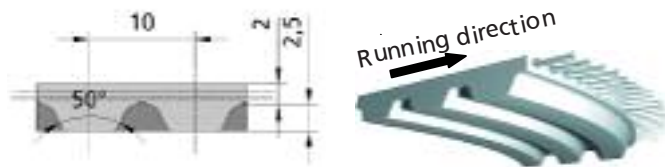

Available endless lengths for BAT 10

- Preferred lengths refer to table
- under 1100 mm: not available
- over 1100 mm: Any number of teeth available, for in-between lengths minimum purchase amount on request
- over 20000 mm on request

Available versions

- **BAT 10:** Standard
- **PAZ:** Nylon tooth facing

Please note, that the BAT timing belt has its self-guiding property only in the stated preferred running direction (see figure above).

Endless lengths			
Type / Length	Number of teeth	Type / Length	Number of teeth
BAT 10 / 1100	110	BAT 10 / 5000	500
BAT 10 / 1150	115	BAT 10 / 5600	560
BAT 10 / 1210	121	BAT 10 / 6000	600
BAT 10 / 1240	124	BAT 10 / 6700	670
BAT 10 / 1250	125	BAT 10 / 7100	710
BAT 10 / 1320	132	BAT 10 / 7500	750
BAT 10 / 1400	140		
BAT 10 / 1500	150		
BAT 10 / 1600	160		
BAT 10 / 1700	170		
		current maximum manufacturing length:	
BAT 10 / 1800	180	BAT 10 / 20000	2000
BAT 10 / 1900	190		
BAT 10 / 2000	200		
BAT 10 / 2240	224		
BAT 10 / 2500	250		
BAT 10 / 2800	280		
BAT 10 / 3000	300		
BAT 10 / 3550	355		
BAT 10 / 4000	400		
BAT 10 / 4500	450		

Belt widths b [mm]: 32 50 75 100

Order example:

BRECOFLEX®-TIMING BELT 50 BAT 10 / 2000

Belt width in mm _____

Type / Pitch _____

Belt length in mm _____

Technical data of the BRECOFLEX® TIMING BELT

BAT 10

Belt width b[cm]

$$b = \frac{F_U}{z_e \cdot F_{U\text{spec}}} \quad F_U [\text{N}]$$

$$b = \frac{100 \cdot M}{z_1 \cdot z_e \cdot M_{\text{spec}}} \quad M [\text{Nm}]$$

$$b = \frac{1000 \cdot P}{z_1 \cdot z_e \cdot P_{\text{spec}}} \quad P [\text{kW}]$$

Drive load bearing characteristics

with given belt width [cm]

$$F_U = F_{U\text{spec}} \cdot z_e \cdot b \quad [\text{N}]$$

$$M = \frac{M_{\text{spec}} \cdot z_1 \cdot z_e \cdot b}{100} \quad [\text{Nm}]$$

$$P = \frac{P_{\text{spec}} \cdot z_1 \cdot z_e \cdot b}{1000} \quad [\text{kW}]$$

intermeshing number of teeth

$$z_{\text{emax}} = 12$$

$$z_e = \frac{z_1 \cdot \arccos \frac{t \cdot (z_2 - z_1)}{2\pi \cdot a}}{180}$$

1. Tooth shear strength (specific belt tooth load bearing)



R.p.m. n [rpm]	$F_{U\text{spec}}$ [N/cm]	M_{spec} [Ncm/cm]	P_{spec} [W/cm]	R.p.m. n [rpm]	$F_{U\text{spec}}$ [N/cm]	M_{spec} [Ncm/cm]	P_{spec} [W/cm]
0	77,91	12,40	0,00	2800	37,63	6,00	17,57
20	76,74	12,22	0,26	3000	36,57	5,83	18,31
40	75,68	12,05	0,50	3200	35,62	5,67	19,00
60	74,73	11,88	0,75	3400	34,66	5,51	19,64
80	73,78	11,73	0,98	3600	33,81	5,37	20,26
100	72,82	11,60	1,21	3800	32,97	5,24	20,85
200	68,90	10,97	2,30	4000	32,12	5,11	21,41
300	65,83	10,47	3,29	4500	30,53	4,81	22,68
400	63,07	10,05	4,21	5000	28,51	4,55	23,85
500	60,84	9,68	5,07	5500	27,03	4,30	24,80
600	58,83	9,36	5,88	6000	25,65	4,08	25,65
700	56,92	9,06	6,65	6500	24,38	3,87	26,39
800	55,33	8,81	7,38	7000	23,11	3,68	27,03
900	53,85	8,56	8,08	7500	22,05	3,50	27,56
1000	52,47	8,35	8,75	8000	20,96	3,34	27,98
1100	51,20	8,15	9,39	8500	19,97	3,18	28,30
1200	50,03	7,96	10,01	9000	19,03	3,03	28,51
1300	48,97	7,79	10,60	9500	18,15	2,88	28,73
1400	47,91	7,62	11,17	10000	17,30	2,76	28,83
1500	46,96	7,46	11,73				
1600	46,00	7,32	12,26				
1700	45,16	7,19	12,78				
1800	44,31	7,05	13,29				
1900	43,46	6,92	13,78				
2000	42,72	6,81	14,25				
2200	41,34	6,57	15,16				
2400	40,07	6,37	16,01				
2600	38,80	6,18	16,81				

Rotational speeds over 10000 rpm and/or belt speeds over 60 m/s are in need of a special drive design. Please request for our advice.

2. Tension cord strength (permitted tensile force of the belt F_{adm}), belt weight

Belt width	b	[mm]	32	50	75	100
BRECOFLEX®	F_{adm}	[N]	4750	7750	12000	16000
Belt weight	BAT 10	[kg/m]	0,180	0,290	0,436	0,581

3. Flexibility (Minimum numbers of teeth, minimum diameter)

Drive type	BFX BAT 10		
without contraflexure	Synchronising pulley	z_{min}	20
	Tension roller (smooth), running on teeth	d_{min} [mm]	60
with contraflexure	Synchronising pulley	z_{min}	25
	Tension roller (smooth), running on the back of the belt	d_{min} [mm]	120

Self-guiding timing belts - endless

BRECOFLEX® TIMING BELT (BFX) with curved teeth and tracking

BATK 10



Available endless lengths for BATK 10

- Preferred lengths refer to table
- under 1100 mm: not available
- over 1100 mm: Any number of teeth available, request minimum purchase amount for intermediate lengths.
- over 20000 mm on request

Available versions

- **BATK 10:** Standard
- **PAZ:** Nylon tooth facing, Textile colour: white

Endless lengths			
Type / Length	Number of teeth	Type / Length	Number of teeth
BATK10 / 1100	110	BATK10 / 5000	500
BATK10 / 1150	115	BATK10 / 5600	560
BATK10 / 1210	121	BATK10 / 6000	600
BATK10 / 1240	124	BATK10 / 6700	670
BATK10 / 1250	125	BATK10 / 7100	710
BATK10 / 1320	132	BATK10 / 7500	750
BATK10 / 1400	140		
BATK10 / 1500	150		
BATK10 / 1600	160		
BATK10 / 1700	170		
		current maximum manufacturing length:	
BATK10 / 1800	180	BATK10 / 20000	2000
BATK10 / 1900	190		
BATK10 / 2000	200		
BATK10 / 2240	224		
BATK10 / 2500	250		
BATK10 / 2800	280		
BATK10 / 3000	300		
BATK10 / 3550	355		
BATK10 / 4000	400		
BATK10 / 4500	450		

Belt widths b [mm]: 32 50 75 100

Order example:

BRECOFLEX®-TIMING BELT 50 BATK 10 / 2000

Belt width in mm _____
 Type / Pitch _____
 Belt length in mm _____

Technical data of the BRECOFLEX® TIMING BELT

BATK 10

Belt width b[cm]

$$b = \frac{F_U}{z_e \cdot F_{U\text{spec}}} \quad F_U[\text{N}]$$

$$b = \frac{100 \cdot M}{z_1 \cdot z_e \cdot M_{\text{spec}}} \quad M[\text{Nm}]$$

$$b = \frac{1000 \cdot P}{z_1 \cdot z_e \cdot P_{\text{spec}}} \quad P[\text{kW}]$$

Drive load bearing characteristics
with given belt width [cm]

$$F_U = F_{U\text{spec}} \cdot z_e \cdot b \quad [\text{N}]$$

$$M = \frac{M_{\text{spec}} \cdot z_1 \cdot z_e \cdot b}{100} \quad [\text{Nm}]$$

$$P = \frac{P_{\text{spec}} \cdot z_1 \cdot z_e \cdot b}{1000} \quad [\text{kW}]$$

intermeshing number of teeth

$$z_{\text{emax}} = 12$$

$$z_e = \frac{z_1}{180} \cdot \arccos \frac{t \cdot (z_2 - z_1)}{2\pi \cdot a}$$

1. Tooth shear strength (specific belt tooth load bearing)



R.p.m. n [rpm]	F _{U spec} [N/cm]	M _{spec} [Ncm/cm]	P _{spec} [W/cm]	R.p.m. n [rpm]	F _{U spec} [N/cm]	M _{spec} [Ncm/cm]	P _{spec} [W/cm]
0	77,91	12,40	0,00	2800	37,63	6,00	17,57
20	76,74	12,22	0,26	3000	36,57	5,83	18,31
40	75,68	12,05	0,50	3200	35,62	5,67	19,00
60	74,73	11,88	0,75	3400	34,66	5,51	19,64
80	73,78	11,73	0,98	3600	33,81	5,37	20,26
100	72,82	11,60	1,21	3800	32,97	5,24	20,85
200	68,90	10,97	2,30	4000	32,12	5,11	21,41
300	65,83	10,47	3,29	4500	30,53	4,81	22,68
400	63,07	10,05	4,21	5000	28,51	4,55	23,85
500	60,84	9,68	5,07	5500	27,03	4,30	24,80
600	58,83	9,36	5,88	6000	25,65	4,08	25,65
700	56,92	9,06	6,65	6500	24,38	3,87	26,39
800	55,33	8,81	7,38	7000	23,11	3,68	27,03
900	53,85	8,56	8,08	7500	22,05	3,50	27,56
1000	52,47	8,35	8,75	8000	20,96	3,34	27,98
1100	51,20	8,15	9,39	8500	19,97	3,18	28,30
1200	50,03	7,96	10,01	9000	19,03	3,03	28,51
1300	48,97	7,79	10,60	9500	18,15	2,88	28,73
1400	47,91	7,62	11,17	10000	17,30	2,76	28,83
1500	46,96	7,46	11,73				
1600	46,00	7,32	12,26				
1700	45,16	7,19	12,78				
1800	44,31	7,05	13,29				
1900	43,46	6,92	13,78				
2000	42,72	6,81	14,25				
2200	41,34	6,57	15,16				
2400	40,07	6,37	16,01				
2600	38,80	6,18	16,81				

Rotational speeds over 10000 rpm and/or belt speeds over 60 m/s are in need of a special drive design. Please request for our advice.

2. Tension cord strength (permitted tensile force of the belt F_{adm}), belt weight

Belt width	b	[mm]	32	50	75	100
BRECOFLEX®	F _{adm}	[N]	4750	7750	12000	16000
Belt weight	BATK 10	[kg/m]	0,192	0,300	0,450	0,600

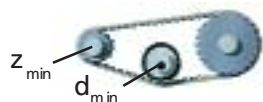
3. Flexibility (Minimum numbers of teeth, minimum diameter)

Drive type	BFX BATK10		
without contraflexure	Synchronising pulley	z _{min}	20
	Tension roller (smooth), running on teeth	d _{min} [mm]	60
with contraflexure	Synchronising pulley	z _{min}	25
	Tension roller (smooth), running on the back of the belt	d _{min} [mm]	120

Self-guiding timing belts - endless

Self-guiding BRECOFLEX® TIMING BELT (BFX)

SFAT 10

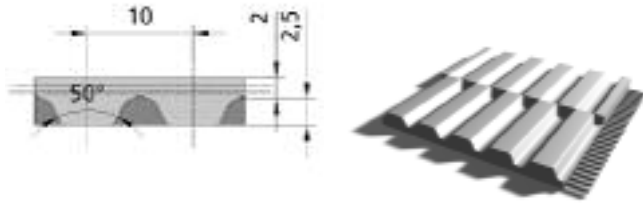

Available endless lengths for SFAT 10

- Preferred lengths refer to table
- under 1100 mm: Not available
- over 1100 mm: Any number of teeth available, request minimum purchase amount for in-between lengths
- over 20000 mm on request

Endless lengths		Type / Length		Number of teeth	
SFAT 10 / 1100	110	SFAT 10 / 4000	400		
SFAT 10 / 1200	120	SFAT 10 / 4500	450		
SFAT 10 / 1300	130	SFAT 10 / 5000	500		
SFAT 10 / 1400	140	SFAT 10 / 5600	560		
SFAT 10 / 1500	150	SFAT 10 / 6000	600		
SFAT 10 / 1600	160	SFAT 10 / 6700	670		
SFAT 10 / 1700	170	SFAT 10 / 7100	710		
SFAT 10 / 1800	180	SFAT 10 / 7500	750		
SFAT 10 / 1900	190				
SFAT 10 / 2000	200				
SFAT 10 / 2240	224				
SFAT 10 / 2500	250				
SFAT 10 / 2800	280				
SFAT 10 / 3000	300				
SFAT 10 / 3550	355				
		current maximum manufacturing length:			
		SFAT 10 / 20000	2000		

Preferred belt width b [mm] 50 75 100

Available versions:

- SFAT 10: Standard
- PAZ: Nylon tooth facing

Order example:

BRECOFLEX®-TIMING BELT 50 SFAT10 / 2000

Belt width in mm _____

Type / Pitch _____

Belt length in mm _____

Technical data of the BRECOFLEX® TIMING BELT SFAT 10

Belt width b[cm]

$$b = \frac{F_U}{z_e \cdot F_{U\text{spec}}} \quad F_U [\text{N}]$$

$$b = \frac{100 \cdot M}{z_1 \cdot z_e \cdot M_{\text{spec}}} \quad M [\text{Nm}]$$

$$b = \frac{1000 \cdot P}{z_1 \cdot z_e \cdot P_{\text{spec}}} \quad P [\text{kW}]$$

Drive load bearing characteristics
with given belt width [cm]

$$F_U = F_{U\text{spec}} \cdot z_e \cdot b \quad [\text{N}]$$

$$M = \frac{M_{\text{spec}} \cdot z_1 \cdot z_e \cdot b}{100} \quad [\text{Nm}]$$

$$P = \frac{P_{\text{spec}} \cdot z_1 \cdot z_e \cdot b}{1000} \quad [\text{kW}]$$

intermeshing number of teeth

$$z_{e\text{max}} = 12$$

$$z_e = \frac{z_1}{180} \cdot \arccos \frac{t \cdot (z_2 - z_1)}{2\pi \cdot a}$$

1. Tooth shear strength (specific belt tooth load bearing)



R.p.m. n [rpm]	F _{U spec} [N/cm]	M _{spec} [Ncm/cm]	P _{spec} [W/cm]	R.p.m. n [rpm]	F _{U spec} [N/cm]	M _{spec} [Ncm/cm]	P _{spec} [W/cm]
0	73,5	11,70	0,000	2800	35,50	5,66	16,58
20	72,4	11,53	0,241	3000	34,50	5,50	17,27
40	71,4	11,37	0,476	3200	33,60	5,35	17,92
60	70,5	11,21	0,705	3400	32,70	5,20	18,53
80	69,6	11,07	0,928	3600	31,90	5,07	19,11
100	68,7	10,94	1,145	3800	31,10	4,94	19,67
200	65,0	10,35	2,170	4000	30,30	4,82	20,20
300	62,1	9,88	3,100	4500	28,50	4,54	21,40
400	59,5	9,48	3,970	5000	26,90	4,29	22,50
500	57,4	9,13	4,780	5500	25,50	4,06	23,40
600	55,5	8,83	5,550	6000	24,20	3,85	24,20
700	53,7	8,55	6,270	6500	23,00	3,65	24,90
800	52,2	8,31	6,960	7000	21,80	3,47	25,50
900	50,8	8,08	7,620	7500	20,80	3,30	26,00
1000	49,5	7,88	8,250	8000	19,77	3,15	26,40
1100	48,3	7,69	8,860	8500	18,84	3,00	26,70
1200	47,2	7,51	9,440	9000	17,95	2,86	26,90
1300	46,2	7,35	10,000	9500	17,12	2,72	27,10
1400	45,2	7,19	10,540	10000	16,32	2,60	27,20
1500	44,3	7,04	11,070				
1600	43,4	6,91	11,570				
1700	42,6	6,78	12,060				
1800	41,8	6,65	12,540				
1900	41,0	6,53	13,000				
2000	40,3	6,42	13,440				
2200	39,0	6,20	14,300				
2400	37,8	6,01	15,100				
2600	36,6	5,83	15,860				

Rotational speeds over 10000 rpm and/or belt speeds over 60 m/s are in need of a special drive design. Please request for our advice.

2. Tension cord strength (permitted tensile force of the belt F_{adm}), belt weight

Belt width	b	[mm]	50	75	100
BRECOFLEX®	F _{adm}	[N]	7750	12000	16000
Belt weight	SFAT 10	[kg/m]	0,290	0,436	0,581

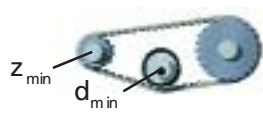
3. Flexibility (Minimum numbers of teeth, minimum diameter)

Drive type	BFX SFAT 10		
without contraflexure	Synchronising pulley	z _{min}	15
	Tension roller (smooth), running on teeth	d _{min} [mm]	50
with contraflexure	Synchronising pulley	z _{min}	25
	Tension roller (smooth), running on the back of the belt	d _{min} [mm]	120

Self-guiding timing belts - endless

Self-guiding BRECOFLEX® TIMING BELT (BFX)

SFAT 15

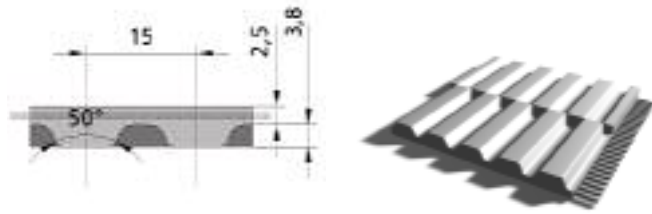

Available endless lengths for SFAT 15

- Preferred lengths refer to table
- under 1500 mm: Not available
- over 1500 mm: Any number of teeth available, request minimum purchase amount for in-between lengths
- over 21990 mm on request

Available versions:

- SFAT 15: Standard
- PAZ: Nylon tooth facing

Endless lengths

Type / length	Number of teeth
SFAT 15 / 1500	100
SFAT 15 / 1590	106
SFAT 15 / 1710	114
SFAT 15 / 1800	120
SFAT 15 / 1905	127
SFAT 15 / 1995	133
SFAT 15 / 2250	150
SFAT 15 / 2505	167
SFAT 15 / 2790	186
SFAT 15 / 3000	200
SFAT 15 / 3495	233
SFAT 15 / 3750	250
SFAT 15 / 4005	267
SFAT 15 / 4500	300
SFAT 15 / 4995	333
SFAT 15 / 5295	353
SFAT 15 / 5595	373
SFAT 15 / 6000	400
SFAT 15 / 6300	420
SFAT 15 / 6705	447

Type / length	Number of teeth
SFAT 15 / 7095	473
SFAT 15 / 7500	500
current maximum manufacturing length:	
SFAT 15 / 21990	1466

Preferred belt width b [mm] 50 75 100

Order example:

BRECOFLEX®-TIMING BELT 100 SFAT15 / 4005

Belt width in mm _____

Type / Pitch _____

Belt length in mm _____

Technical data of the BRECOFLEX® TIMING BELT SFAT 15

Belt width b [cm]

$$b = \frac{F_U}{z_e \cdot F_{U\text{spec}}} \quad F_U [\text{N}]$$

$$b = \frac{100 \cdot M}{z_1 \cdot z_e \cdot M_{\text{spec}}} \quad M [\text{Nm}]$$

$$b = \frac{1000 \cdot P}{z_1 \cdot z_e \cdot P_{\text{spec}}} \quad P [\text{kW}]$$

Drive load bearing characteristics
with given belt width [cm]

$$F_U = F_{U\text{spec}} \cdot z_e \cdot b \quad [\text{N}]$$

$$M = \frac{M_{\text{spec}} \cdot z_1 \cdot z_e \cdot b}{100} \quad [\text{Nm}]$$

$$P = \frac{P_{\text{spec}} \cdot z_1 \cdot z_e \cdot b}{1000} \quad [\text{kW}]$$

intermeshing number of teeth

$$z_{\text{emax}} = 12$$

$$z_e = \frac{z_1}{180} \cdot \arccos \frac{t \cdot (z_2 - z_1)}{2\pi \cdot a}$$



1. Tooth shear strength (specific belt tooth load bearing)

R.p.m. n [rpm]	$F_{U\text{spec}}$ [N/cm]	M_{spec} [Ncm/cm]	P_{spec} [W/cm]	R.p.m. n [rpm]	$F_{U\text{spec}}$ [N/cm]	M_{spec} [Ncm/cm]	P_{spec} [W/cm]
0	110,25	29,250	0,000	2200	53,50	13,200	30,450
20	110,25	28,715	0,601	2400	51,30	12,655	31,810
40	108,30	28,235	1,182	2500	49,25	12,410	32,445
60	106,55	27,755	1,745	2600	48,25	12,115	33,045
80	104,90	27,335	2,291	2800	47,30	11,680	34,165
100	103,30	26,920	2,821	2880	45,50	11,445	34,585
150	101,80	26,015	4,086	3000	44,80	11,200	35,185
200	98,45	25,175	5,278	3200	43,80	10,775	36,100
300	95,40	23,790	7,477	3400	42,25	10,350	36,920
400	90,30	22,640	9,478	3600	40,75	9,985	37,650
500	85,95	21,615	11,321	3800	39,35	9,620	38,300
600	82,30	20,765	13,030	4000	38,05	9,260	38,875
700	79,05	19,975	14,626	4500	36,75	8,470	39,980
730	76,10	19,740	15,085	5000	35,45	7,745	40,675
800	75,35	19,255	16,122	5500	34,15	6,855	41,470
900	73,50	18,590	17,530	6000	32,95	6,135	42,315
1000	71,15	17,990	18,858	6500	31,75	5,235	43,010
1100	68,95	17,445	20,115	Rotational speeds over 6500 rpm and/or belt speeds over 40 m/s are in need of a special drive design. Please request for our advice.			
1200	66,95	16,955	21,305				
1300	65,05	16,475	22,435				
1400	63,35	16,045	23,509				
1460	61,70	15,800	24,128				
1500	60,70	15,620	24,530				
1600	60,15	15,205	25,502				
1700	58,65	14,840	26,429				
1800	57,30	14,475	27,311				
1900	55,95	14,165	28,153				
2000	54,70	13,810	28,955				

2. Tension cord strength (permitted tensile force of the belt F_{adm}), belt weight

Belt width	b	[mm]	50	75	100
BRECOFLEX®	F_{adm}	[N]	10000	15600	21200
Belt weight	SFAT 15	[kg/m]	0,440	0,660	0,875

3. Flexibility (Minimum numbers of teeth, minimum diameter)

Drive type	BFX SFAT 15		
without contraflexure	Synchronising pulley	z_{min}	20
	Tension roller (smooth), running on teeth	d_{min} [mm]	100
with contraflexure	Synchronising pulley	z_{min}	25
	Tension roller (smooth), running on the back of the belt	d_{min} [mm]	150

Self-guiding timing belts - endless

Self-guiding BRECOFLEX® TIMING BELT (BFX)

SFAT 20

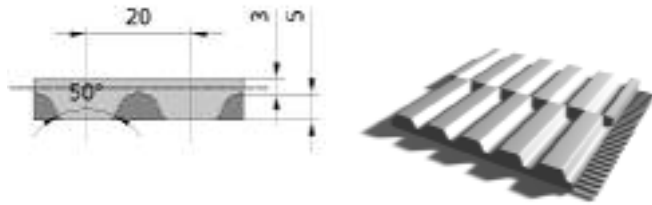

Available endless lengths for SFAT 20

- Preferred lengths refer to table
- under 1500 mm: Not available
- over 1500 mm: Any number of teeth available, request minimum purchase amount for in-between lengths
- over 20000 mm on request

Available versions:

- **SFAT 20:** Standard
- **PAZ:** Nylon tooth facing

Endless lengths

Type / Length	Number of teeth	Type / Length	Number of teeth
SFAT 20 / 1500	75	SFAT 20 / 5600	280
SFAT 20 / 1600	80	SFAT 20 / 6000	300
SFAT 20 / 1700	85	SFAT 20 / 6700	335
SFAT 20 / 1800	90	SFAT 20 / 7100	355
SFAT 20 / 1900	95	SFAT 20 / 7500	375
SFAT 20 / 2000	100		
SFAT 20 / 2240	112	current maximum manufacturing length:	
SFAT 20 / 2500	125		
SFAT 20 / 2800	140		
SFAT 20 / 3000	150	SFAT 20 / 20000	1000
SFAT 20 / 3560	178		
SFAT 20 / 3760	188		
SFAT 20 / 4000	200		
SFAT 20 / 4500	225		
SFAT 20 / 5000	250		

Preferred belt width b [mm] 50 75 100

Order example:

BRECOFLEX®-TIMING BELT 100 SFAT20 / 4000

Belt width in mm _____

Type / Pitch _____

Belt length in mm _____

Technical data of the BRECOFLEX® TIMING BELT SFAT 20

Belt width b[cm]

$$b = \frac{F_U}{z_e \cdot F_{U\text{spec}}} \quad F_U [\text{N}]$$

$$b = \frac{100 \cdot M}{z_1 \cdot z_e \cdot M_{\text{spec}}} \quad M [\text{Nm}]$$

$$b = \frac{1000 \cdot P}{z_1 \cdot z_e \cdot P_{\text{spec}}} \quad P [\text{kW}]$$

Drive load bearing

characteristics

with given belt width [cm]

$$F_U = F_{U\text{spec}} \cdot z_e \cdot b \quad [\text{N}]$$

$$M = \frac{M_{\text{spec}} \cdot z_1 \cdot z_e \cdot b}{100} \quad [\text{Nm}]$$

$$P = \frac{P_{\text{spec}} \cdot z_1 \cdot z_e \cdot b}{1000} \quad [\text{kW}]$$

intermeshing number of teeth

$$z_{\text{emax}} = 12$$

$$z_e = \frac{z_1}{180} \cdot \arccos \frac{t \cdot (z_2 - z_1)}{2\pi \cdot a}$$

1. Tooth shear strength (specific belt tooth load bearing)



R.p.m. n [rpm]	F _{U spec} [N/cm]	M _{spec} [Ncm/cm]	P _{spec} [W/cm]	R.p.m. n [rpm]	F _{U spec} [N/cm]	M _{spec} [Ncm/cm]	P _{spec} [W/cm]
0	147,0	46,80	0,000	2800	55,5	17,65	51,8
20	144,2	45,90	0,962	3000	53,1	16,90	53,1
40	141,7	45,10	1,889	3200	50,9	16,20	54,3
60	139,3	44,30	2,790	3400	48,8	15,53	55,3
80	137,0	43,60	3,650	3600	46,8	14,91	56,2
100	134,9	42,90	4,500	3800	45,0	14,31	56,9
200	125,8	40,00	8,390	4000	43,2	13,74	57,6
300	118,5	37,70	11,850	4500	39,0	12,43	58,6
400	112,4	35,80	14,990	5000	35,3	11,25	58,8
500	107,2	34,10	17,860	5500	32,0	10,17	60,6
600	102,6	32,70	20,500	6000	28,9	9,19	61,7
700	98,5	31,40	23,000	6500	26,0	8,28	62,4
800	94,8	30,20	25,300				
900	91,5	29,10	27,400				
1000	88,4	28,10	29,500				
1100	85,6	27,20	31,400				
1200	82,9	26,40	33,200				
1300	80,5	25,60	34,900				
1400	78,2	24,90	36,500				
1500	76,0	24,20	38,000				
1600	73,9	23,50	39,400				
1700	72,0	22,90	40,800				
1800	70,1	22,30	42,100				
1900	68,4	21,80	43,300				
2000	66,7	21,20	44,500				
2200	63,6	20,20	46,600				
2400	60,7	19,31	48,500				
2600	58,0	18,45	50,200				

Rotational speeds over 6500 rpm and/or belt speeds over 40 m/s are in need of a special drive design. Please request for our advice.

2. Tension cord strength (permitted tensile force of the belt F_{adm}), belt weight

Belt width	b	[mm]	50	75	100
BRECOFLEX®	F _{adm}	[N]	10000	15600	21200
Belt weight	SFAT 20	[kg/m]	0,480	0,720	0,960

3. Flexibility (Minimum numbers of teeth, minimum diameter)

Drive type	BFX SFAT 20		
without contraflexure	Synchronising pulley	z _{min}	18
	Tension roller (smooth), running on teeth	d _{min} [mm]	120
with contraflexure	Synchronising pulley	z _{min}	25
	Tension roller (smooth), running on the back of the belt	d _{min} [mm]	180

Self-guiding timing belts - endless

Self-guiding BRECOFLEX® TIMING BELT (BFX)

ATK 5 K6-E

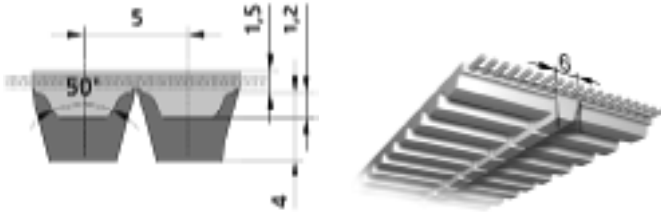

Available endless lengths for ATK 5 K6-E

- Preferred lengths refer to table
- over 1075 mm: Any number of teeth available, request minimum purchase amount for in-between lengths.
- over 15,000 mm on request

Available versions:

- **ATK 5 K6-E:** As standard: single-sided with E tension members
- **PAZ:** Nylon tooth facing

Endless lengths

Type / length	Number of teeth	Type / length	Number of teeth
ATK5K6-E / 1075	215	ATK5K6-E / 4750	950
ATK5K6-E / 1100	220	ATK5K6-E / 5000	1000
ATK5K6-E / 1215	243	ATK5K6-E / 5300	1060
ATK5K6-E / 1380	276	ATK5K6-E / 5600	1120
ATK5K6-E / 1400	280	ATK5K6-E / 6000	1200
ATK5K6-E / 1500	300	ATK5K6-E / 6300	1260
ATK5K6-E / 1600	320	ATK5K6-E / 6700	1340
ATK5K6-E / 1700	340	ATK5K6-E / 7100	1420
ATK5K6-E / 1800	360	ATK5K6-E / 7500	1500
ATK5K6-E / 1900	380		
ATK5K6-E / 2000	400		current maximum manufacturing length:
ATK5K6-E / 2120	424		
ATK5K6-E / 2240	448		
ATK5K6-E / 2360	472		
ATK5K6-E / 2500	500		ATK5K6-E /15000 3000
ATK5K6-E / 2650	530		
ATK5K6-E / 2800	560		
ATK5K6-E / 3000	600		
ATK5K6-E / 3150	630		
ATK5K6-E / 3350	670		
ATK5K6-E / 3550	710		
ATK5K6-E / 3750	750		
ATK5K6-E / 4000	800		
ATK5K6-E / 4250	850		
ATK5K6-E / 4500	900		

Preferred belt width

b [mm]: 50 100

In-between widths upon request

Order example:

BRECOFLEX®-TIMING BELT 50 ATK5K6-E / 1200

Belt width in mm _____
 Type / Pitch _____
 Belt length in mm _____

Technical data of the BRECOFLEX® TIMING BELT

ATK 5 K6-E

Belt width b[cm]

$$b = \frac{F_U}{z_e \cdot F_{U\text{spec}}} \quad F_U[\text{N}]$$

$$b = \frac{100 \cdot M}{z_1 \cdot z_e \cdot M_{\text{spec}}} \quad M[\text{Nm}]$$

$$b = \frac{1000 \cdot P}{z_1 \cdot z_e \cdot P_{\text{spec}}} \quad P[\text{kW}]$$

Drive load bearing characteristics with given belt width [cm]

$$F_U = F_{U\text{spec}} \cdot z_e \cdot b \quad [\text{N}]$$

$$M = \frac{M_{\text{spec}} \cdot z_1 \cdot z_e \cdot b}{100} \quad [\text{Nm}]$$

$$P = \frac{P_{\text{spec}} \cdot z_1 \cdot z_e \cdot b}{1000} \quad [\text{kW}]$$

intermeshing number of teeth

$$z_{\text{emax}} = 12$$

$$z_e = \frac{z_1}{180} \cdot \arccos \frac{t \cdot (z_2 - z_1)}{2\pi \cdot a}$$

1. Tooth shear strength (specific belt tooth load bearing)

R.p.m. n [rpm]	$F_{U\text{spec}}$ [N/cm]	M_{spec} [Ncm/cm]	P_{spec} [W/cm]	R.p.m. n [rpm]	$F_{U\text{spec}}$ [N/cm]	M_{spec} [Ncm/cm]	P_{spec} [W/cm]
0	35,3	2,810	0,000	2800	19,84	1,579	4,63
20	34,9	2,780	0,058	3000	19,42	1,545	4,85
40	34,5	2,750	0,115	3200	19,01	1,513	5,07
60	34,1	2,720	0,171	3400	18,64	1,483	5,28
80	33,8	2,690	0,225	3600	18,28	1,454	5,48
100	33,5	2,660	0,279	3800	17,93	1,427	5,68
200	32,0	2,550	0,534	4000	17,61	1,401	5,87
300	30,9	2,460	0,771	4500	16,86	1,342	6,32
400	29,8	2,370	0,995	5000	16,18	1,288	6,74
500	29,0	2,300	1,207	5500	15,56	1,239	7,13
600	28,2	2,240	1,409	6000	15,00	1,194	7,50
700	27,5	2,190	1,603	6500	14,48	1,152	7,84
800	26,8	2,140	1,789	7000	13,99	1,113	8,16
900	26,3	2,090	1,969	7500	13,54	1,077	8,46
1000	25,7	2,050	2,140	8000	13,11	1,043	8,74
1100	25,2	2,010	2,310	8500	12,71	1,011	9,00
1200	24,8	1,970	2,480	9000	12,33	0,981	9,24
1300	24,3	1,936	2,640	9500	11,97	0,953	9,47
1400	23,9	1,903	2,790	10000	11,63	0,925	9,69
1500	23,5	1,872	2,940				
1600	23,2	1,843	3,090				
1700	22,8	1,816	3,230				
1800	22,5	1,789	3,370				
1900	22,2	1,764	3,510				
2000	21,9	1,740	3,650				
2200	21,3	1,695	3,910				
2400	20,8	1,654	4,160				
2600	20,3	1,615	4,400				

Rotational speeds over 10000 rpm and/ or belt speeds over 80 m/s are in need of a special drive design. Please request for our advice.

2. Tension cord strength (permitted tensile force of the belt F_{adm}), belt weight

Belt width	b	[mm]	50	100
BRECOFLEX®	F_{adm}	[N]	4200	8610
Belt weight	ATK5K6-E	[kg/m]	0,167	0,334

3. Flexibility (Minimum numbers of teeth, minimum diameter)

Drive type	BFX ATK 5 K6-E		
without contraflexure	Synchronising pulley	z_{min}	25
	Tension roller (smooth), running on teeth	d_{min} [mm]	40
with contraflexure	Synchronising pulley	z_{min}	25
	Tension roller (smooth), running on the back of the belt	d_{min} [mm]	80

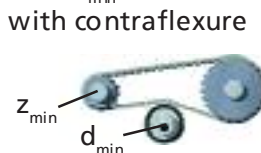

Self-guiding timing belts - endless

Self-guiding BRECOFLEX® TIMING BELT (BFX)

ATK 10 K6

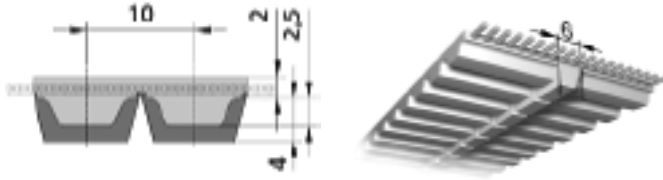

ATK 10 K6-DL

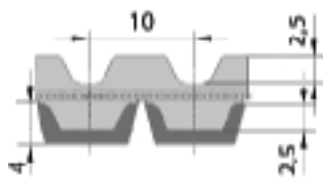

ATK 10 K6-DR

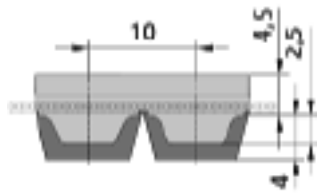

Available endless lengths for ATK 10 K6

- Preferred lengths refer to table
- under 1500 mm: not available
- over 1500 mm: Any number of teeth available, request minimum purchase amount for in-between lengths
- over 20000 mm on request.

Available versions:

- **ATK 10 K6:** Standard, single-sided
- **DL:** Standard, double-sided, minimum purchase amount on request
- **PAZ:** Nylon tooth facing
- **DL-PAZ:** Double-sided self-tracking belt with nylon facing on the track-guided tooth side, minimum purchase amount on request
- **DR, DR-PAZ:** Reinforced back of the belt, through 2.5 mm larger belt thickness, minimum purchase amount on request

Endless lengths

Type / length	Number of teeth	Type / length	Number of teeth
ATK10 K6 / 1500	150	ATK10 K6 / 6300	630
ATK10 K6 / 1600	160	ATK10 K6 / 6700	670
ATK10 K6 / 1700	170	ATK10 K6 / 7100	710
ATK10 K6 / 1800	180	ATK10 K6 / 7500	750
ATK10 K6 / 1900	190	ATK10 K6 / 8000	800
ATK10 K6 / 2000	200		
ATK10 K6 / 2120	212		
ATK10 K6 / 2240	224		
ATK10 K6 / 2360	236		
ATK10 K6 / 2500	250		
ATK10 K6 / 2650	265		
ATK10 K6 / 2800	280		
ATK10 K6 / 3000	300		
ATK10 K6 / 3150	315		
ATK10 K6 / 3350	335		
ATK10 K6 / 3550	355		
ATK10 K6 / 3750	375		
ATK10 K6 / 4000	400		
ATK10 K6 / 4250	425		
ATK10 K6 / 4500	450		
ATK10 K6 / 4750	475		
ATK10 K6 / 5000	500		
ATK10 K6 / 5300	530		
ATK10 K6 / 5600	560		
ATK10 K6 / 6000	600		

current maximum manufacturing length:
ATK10K6 / 20000 2000

Preferred belt width b mm 50 100

In-between widths upon request

Order example:

BRECOFLEX®-TIMING BELT 50 ATK 10 K6 / 6000 PAZ

Belt width in mm _____

Type / Pitch _____

Belt length in mm _____

Nylon facing on the tooth side _____

Technical data of the BRECOFLEX® TIMING BELT ATK 10 K6, ATK 10 K6-DL, ATK 10 K6-DR

Belt width b[cm]

$$b = \frac{F_U}{z_e \cdot F_{U\text{spec}}} \quad F_U [\text{N}]$$

$$b = \frac{100 \cdot M}{z_1 \cdot z_e \cdot M_{\text{spec}}} \quad M [\text{Nm}]$$

$$b = \frac{1000 \cdot P}{z_1 \cdot z_e \cdot P_{\text{spec}}} \quad P [\text{kW}]$$

Drive load bearing characteristics
with given belt width [cm]

$$F_U = F_{U\text{spec}} \cdot z_e \cdot b \quad [\text{N}]$$

$$M = \frac{M_{\text{spec}} \cdot z_1 \cdot z_e \cdot b}{100} \quad [\text{Nm}]$$

$$P = \frac{P_{\text{spec}} \cdot z_1 \cdot z_e \cdot b}{1000} \quad [\text{kW}]$$

intermeshing number of teeth

$$z_{\text{emax}} = 12$$

$$z_e = \frac{z_1}{180} \cdot \arccos \frac{t \cdot (z_2 - z_1)}{2\pi \cdot a}$$

1. Tooth shear strength (specific belt tooth load bearing)



R.p.m. n [rpm]	$F_{U\text{spec}}$ [N/cm]	M_{spec} [Ncm/cm]	P_{spec} [W/cm]	R.p.m. n [rpm]	$F_{U\text{spec}}$ [N/cm]	M_{spec} [Ncm/cm]	P_{spec} [W/cm]
0	73,5	11,70	0,000	2800	35,50	5,66	16,58
20	72,4	11,53	0,241	3000	34,50	5,50	17,27
40	71,4	11,37	0,476	3200	33,60	5,35	17,92
60	70,5	11,21	0,705	3400	32,70	5,20	18,53
80	69,6	11,07	0,928	3600	31,90	5,07	19,11
100	68,7	10,94	1,145	3800	31,10	4,94	19,67
200	65,0	10,35	2,170	4000	30,30	4,82	20,20
300	62,1	9,88	3,100	4500	28,50	4,54	21,40
400	59,5	9,48	3,970	5000	26,90	4,29	22,50
500	57,4	9,13	4,780	5500	25,50	4,06	23,40
600	55,5	8,83	5,550	6000	24,20	3,85	24,20
700	53,7	8,55	6,270	6500	23,00	3,65	24,90
800	52,2	8,31	6,960	7000	21,80	3,47	25,50
900	50,8	8,08	7,620	7500	20,80	3,30	26,00
1000	49,5	7,88	8,250	8000	19,77	3,15	26,40
1100	48,3	7,69	8,860	8500	18,84	3,00	26,70
1200	47,2	7,51	9,440	9000	17,95	2,86	26,90
1300	46,2	7,35	10,000	9500	17,12	2,72	27,10
1400	45,2	7,19	10,540	10000	16,32	2,60	27,20
1500	44,3	7,04	11,070				
1600	43,4	6,91	11,570				
1700	42,6	6,78	12,060				
1800	41,8	6,65	12,540				
1900	41,0	6,53	13,000				
2000	40,3	6,42	13,440				
2200	39,0	6,20	14,300				
2400	37,8	6,01	15,100				
2600	36,6	5,83	15,860				

Rotational speeds over 10000 rpm and/or belt speeds over 60 m/s are in need of a special drive design. Please request for our advice.

2. Tension cord strength (permitted tensile force of the belt F_{adm}), belt weight

Belt width	b	[mm]	50	100
BRECOFLEX®	F_{adm}	[N]	7750	16000
Belt weight	ATK 10 K6	[kg/m]	0,290	0,581
	ATK10K6-DL	[kg/m]	0,386	0,766
	ATK10K6-DR	[kg/m]	0,445	0,886

3. Flexibility (Minimum numbers of teeth, minimum diameter)

Drive type		BFX ATK10K6	BFX ATK10K6-DL	BFX ATK10K6-DR	
without contraflexure 	Synchronising pulley	z_{min}	20	25	25*
	Tension roller (smooth), running on teeth	d_{min} [mm]	80	80	80
with contraflexure 	Synchronising pulley	z_{min}	25	25	25
	Tension roller (smooth), running on the back of the belt	d_{min} [mm]	120	120	120

*Rotational speed limitation

Self-guiding timing belts - endless

Self-guiding BRECOFLEX® TIMING BELT (BFX)

TK 5 K6

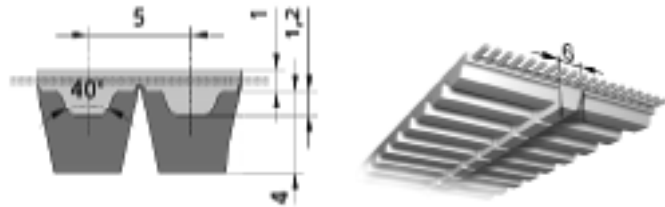

Available endless lengths for TK 5 K6

- Preferred lengths refer to table
- over 1050 mm: Any number of teeth available, request minimum purchase amount for in-between lengths.
- over 15,000 mm on request

Available versions:

- **TK 5 K6:** Standard, single-sided
- **PAZ:** Nylon tooth facing

Endless lengths

Type / length	Number of teeth	Type / length	Number of teeth
TK5K6 / 1075	215	TK5K6 / 4750	950
TK5K6 / 1100	220	TK5K6 / 5000	1000
TK5K6 / 1215	243	TK5K6 / 5300	1060
TK5K6 / 1380	276	TK5K6 / 5600	1120
TK5K6 / 1400	280	TK5K6 / 6000	1200
TK5K6 / 1500	300	TK5K6 / 6300	1260
TK5K6 / 1600	320	TK5K6 / 6700	1340
TK5K6 / 1700	340	TK5K6 / 7100	1420
TK5K6 / 1800	360	TK5K6 / 7500	1500
TK5K6 / 1900	380		
TK5K6 / 2000	400		
TK5K6 / 2120	424		
TK5K6 / 2240	448		
TK5K6 / 2360	472		
TK5K6 / 2500	500		
TK5K6 / 2650	530		
TK5K6 / 2800	560		
TK5K6 / 3000	600		
TK5K6 / 3150	630		
TK5K6 / 3350	670		
TK5K6 / 3550	710		
TK5K6 / 3750	750		
TK5K6 / 4000	800		
TK5K6 / 4250	850		
TK5K6 / 4500	900		

current maximum manufacturing length:

TK5K6 / 15000 3000

Preferred belt width

b [mm]: 50 100

In-between widths upon request

Order example:

BRECOFLEX®-TIMING BELT 50 TK5K6 / 1500

Belt width in mm _____
 Type / Pitch _____
 Belt length in mm _____

Technical data of the BRECOFLEX® TIMING BELT

TK 5 K6

Belt width b[cm]

$$b = \frac{F_U}{z_e \cdot F_{U\text{spec}}} \quad F_U [\text{N}]$$

$$b = \frac{100 \cdot M}{z_1 \cdot z_e \cdot M_{\text{spec}}} \quad M [\text{Nm}]$$

$$b = \frac{1000 \cdot P}{z_1 \cdot z_e \cdot P_{\text{spec}}} \quad P [\text{kW}]$$

Drive load bearing characteristics

with given belt width [cm]

$$F_U = F_{U\text{spec}} \cdot z_e \cdot b \quad [\text{N}]$$

$$M = \frac{M_{\text{spec}} \cdot z_1 \cdot z_e \cdot b}{100} \quad [\text{Nm}]$$

$$P = \frac{P_{\text{spec}} \cdot z_1 \cdot z_e \cdot b}{1000} \quad [\text{kW}]$$

intermeshing number of teeth

$$z_{\text{emax}} = 12$$

$$z_e = \frac{z_1 \cdot \arccos \frac{t \cdot (z_2 - z_1)}{2\pi \cdot a}}{180}$$

1. Tooth shear strength (specific belt tooth load bearing)

R.p.m. n [rpm]	$F_{U\text{spec}}$ [N/cm]	M_{spec} [Ncm/cm]	P_{spec} [W/cm]	R.p.m. n [rpm]	$F_{U\text{spec}}$ [N/cm]	M_{spec} [Ncm/cm]	P_{spec} [W/cm]
0	24,00	1,910	0,000	2800	12,59	1,002	2,94
20	23,40	1,861	0,039	3000	12,37	0,984	3,09
40	22,90	1,819	0,076	3200	12,16	0,967	3,24
60	22,40	1,783	0,112	3400	11,96	0,951	3,39
80	22,00	1,751	0,147	3600	11,77	0,936	3,53
100	21,70	1,723	0,180	3800	11,59	0,922	3,67
200	20,30	1,614	0,338	4000	11,42	0,909	3,81
300	19,30	1,536	0,483	4500	11,03	0,878	4,14
400	18,55	1,476	0,618	5000	10,68	0,850	4,45
500	17,93	1,427	0,747	5500	10,36	0,825	4,75
600	17,41	1,385	0,870	6000	10,07	0,802	5,04
700	16,96	1,349	0,989	6500	9,81	0,780	5,31
800	16,56	1,318	1,104	7000	9,56	0,761	5,58
900	16,20	1,289	1,215	7500	9,33	0,742	5,83
1000	15,88	1,263	1,323	8000	9,11	0,725	6,08
1100	15,58	1,240	1,428	8500	8,91	0,709	6,31
1200	15,31	1,218	1,531	9000	8,72	0,694	6,54
1300	15,06	1,198	1,632	9500	8,54	0,679	6,76
1400	14,83	1,180	1,730	10000	8,37	0,666	6,97
1500	14,61	1,162	1,826				
1600	14,40	1,146	1,920				
1700	14,21	1,131	2,010				
1800	14,03	1,116	2,100				
1900	13,85	1,102	2,190				
2000	13,69	1,089	2,280				
2200	13,38	1,065	2,450				
2400	13,10	1,042	2,620				
2600	12,84	1,021	2,780				

Rotational speeds over 10000 rpm and/or belt speeds over 80 m/s are in need of a special drive design. Please request for our advice.

2. Tension cord strength (permitted tensile force of the belt F_{adm}), belt weight

Belt width	b	[mm]	50	100
BRECOFLEX®	F_{adm}	[N]	1920	3930
Belt weight	TK5K6	[kg/m]	0,123	0,232

3. Flexibility (Minimum numbers of teeth, minimum diameter)

Drive type	BFX TK 5 K6		
without contraflexure	Synchronising pulley	z_{min}	25
	Tension roller (smooth), running on teeth	d_{min} [mm]	40
with contraflexure	Synchronising pulley	z_{min}	25
	Tension roller (smooth), running on the back of the belt	d_{min} [mm]	60

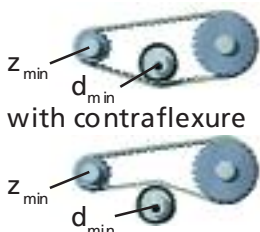

Self-guiding timing belts - endless

Self-guiding BRECOFLEX® TIMING BELT (BFX)

TK 10 K6

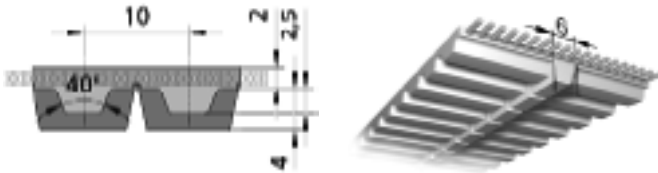

Available endless lengths for TK 10 K6

- Preferred lengths refer to table
- over 1080 mm: Any number of teeth available, request minimum purchase amount for in-between lengths.
- over 20000 mm on request

Available versions:

- **TK 10 K6:** Standard, single-sided
- **PAZ:** Nylon tooth facing

Endless lengths

Type / length	Number of teeth	Type / length	Number of teeth
TK10K6 / 1080	108	TK10K6 / 3150	315
TK10K6 / 1150	115	TK10K6 / 3350	335
TK10K6 / 1210	121	TK10K6 / 3750	375
TK10K6 / 1240	124	TK10K6 / 4000	400
TK10K6 / 1250	125	TK10K6 / 4250	425
TK10K6 / 1320	132	TK10K6 / 4500	450
TK10K6 / 1350	135	TK10K6 / 4750	475
TK10K6 / 1390	139	TK10K6 / 5000	500
TK10K6 / 1400	140	TK10K6 / 5300	530
TK10K6 / 1420	142	TK10K6 / 5600	560
TK10K6 / 1460	146	TK10K6 / 6000	600
TK10K6 / 1500	150	TK10K6 / 6300	630
TK10K6 / 1560	156	TK10K6 / 6700	670
TK10K6 / 1610	161	TK10K6 / 7100	710
TK10K6 / 1750	175	TK10K6 / 7500	750
TK10K6 / 1780	178	TK10K6 / 8000	800
TK10K6 / 1880	188	TK10K6 / 9000	900
TK10K6 / 1960	196		
TK10K6 / 2250	225		
TK10K6 / 2360	236		
TK10K6 / 2500	250		
TK10K6 / 2650	265		
TK10K6 / 2800	280		
TK10K6 / 3000	300		
TK10K6 / 3100	310		

current maximum manufacturing length:

TK10K6 / 20000 20000

Preferred belt width

b [mm]: 50 100

In-between widths upon request

Order example:

BRECOFLEX®-TIMING BELT 50 TK10K6 / 1500

Belt width in mm _____
 Type / Pitch _____
 Beltlength in mm _____

Technical data of the BRECOFLEX® TIMING BELT

TK 10 K6

Belt width b[cm]

$$b = \frac{F_U}{z_e \cdot F_{U\text{spec}}} \quad F_U [\text{N}]$$

$$b = \frac{100 \cdot M}{z_1 \cdot z_e \cdot M_{\text{spec}}} \quad M [\text{Nm}]$$

$$b = \frac{1000 \cdot P}{z_1 \cdot z_e \cdot P_{\text{spec}}} \quad P [\text{kW}]$$

Drive load bearing characteristics with given belt width [cm]

$$F_U = F_{U\text{spec}} \cdot z_e \cdot b \quad [\text{N}]$$

$$M = \frac{M_{\text{spec}} \cdot z_1 \cdot z_e \cdot b}{100} \quad [\text{Nm}]$$

$$P = \frac{P_{\text{spec}} \cdot z_1 \cdot z_e \cdot b}{1000} \quad [\text{kW}]$$

intermeshing number of teeth

$$z_{\text{emax}} = 12$$

$$z_e = \frac{z_1}{180} \cdot \arccos \frac{t \cdot (z_2 - z_1)}{2\pi \cdot a}$$

1. Tooth shear strength (specific belt tooth load bearing)

R.p.m. n [rpm]	$F_{U\text{spec}}$ [N/cm]	M_{spec} [Ncm/cm]	P_{spec} [W/cm]	R.p.m. n [rpm]	$F_{U\text{spec}}$ [N/cm]	M_{spec} [Ncm/cm]	P_{spec} [W/cm]
0	50,5	8,04	0,000	2800	22,70	3,620	10,60
20	49,0	7,80	0,163	3000	22,20	3,530	11,08
40	47,7	7,60	0,318	3200	21,70	3,450	11,55
60	46,6	7,42	0,466	3400	21,20	3,360	11,99
80	45,7	7,27	0,609	3600	20,70	3,300	12,42
100	44,8	7,13	0,746	3800	20,30	3,230	12,84
200	41,4	6,60	1,381	4000	19,86	3,160	13,24
300	39,1	6,22	1,953	4500	18,91	3,010	14,18
400	37,2	5,92	2,480	5000	18,06	2,870	15,05
500	35,7	5,68	2,980	5500	17,28	2,750	15,84
600	34,4	5,48	3,440	6000	16,58	2,640	16,58
700	33,3	5,31	3,890	6500	15,93	2,540	17,26
800	32,4	5,15	4,320	7000	15,33	2,440	17,88
900	31,5	5,01	4,730	7500	14,76	2,350	18,46
1000	30,7	4,89	5,120	8000	14,24	2,270	18,99
1100	30,0	4,77	5,500	8500	13,74	2,180	19,47
1200	29,3	4,67	5,870	9000	13,28	2,110	19,92
1300	28,7	4,57	6,220	9500	12,84	2,040	20,30
1400	28,2	4,48	6,570	10000	12,42	1,976	20,70
1500	27,6	4,40	6,910				
1600	27,1	4,32	7,230				
1700	26,7	4,24	7,550				
1800	26,2	4,17	7,860				
1900	25,8	4,10	8,160				
2000	25,4	4,04	8,460				
2200	24,6	3,92	9,030				
2400	23,9	3,81	9,580				
2600	23,3	3,71	10,100				

Rotational speeds over 10000 rpm and/or belt speeds over 80 m/s are in need of a special drive design. Please request for our advice.

2. Tension cord strength (permitted tensile force of the belt F_{adm}), belt weight

Belt width	b	[mm]	50	100
BRECOFLEX®	F_{adm}	[N]	3800	7800
Belt weight	TK10K6	[kg/m]	0,235	0,458

3. Flexibility (Minimum numbers of teeth, minimum diameter)

Drive type	BFX TK 10 K6		
without contraflexure	Synchronising pulley	z_{min}	20
	Tension roller (smooth), running on teeth	d_{min} [mm]	60
with contraflexure	Synchronising pulley	z_{min}	25
	Tension roller (smooth), running on the back of the belt	d_{min} [mm]	80

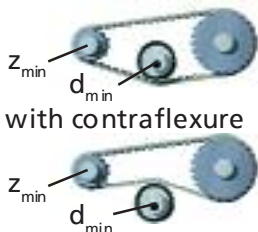

Self-guiding timing belts - endless

Self-guiding BRECOFLEX® TIMING BELT (BFX)

TK 10 K13

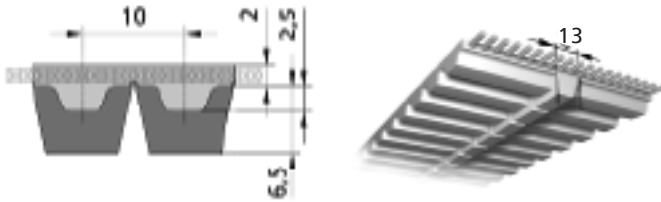

Available endless lengths for TK 10 K13

- Preferred lengths refer to table
- over 1080 mm: Any number of teeth available, request minimum purchase amount for in-between lengths.
- over 20000 mm on request

Available versions:

- **TK 10 K13:** Standard, single-sided
- **PAZ:** Nylon tooth facing

Endless lengths

Type / length	Number of teeth	Type / length	Number of teeth
TK10K13 / 1080	108	TK10K13 / 3150	315
TK10K13 / 1150	115	TK10K13 / 3350	335
TK10K13 / 1210	121	TK10K13 / 3750	375
TK10K13 / 1240	124	TK10K13 / 4000	400
TK10K13 / 1250	125	TK10K13 / 4250	425
TK10K13 / 1320	132	TK10K13 / 4500	450
TK10K13 / 1350	135	TK10K13 / 4750	475
TK10K13 / 1390	139	TK10K13 / 5000	500
TK10K13 / 1400	140	TK10K13 / 5300	530
TK10K13 / 1420	142	TK10K13 / 5600	560
TK10K13 / 1460	146	TK10K13 / 6000	600
TK10K13 / 1500	150	TK10K13 / 6300	630
TK10K13 / 1560	156	TK10K13 / 6700	670
TK10K13 / 1610	161	TK10K13 / 7100	710
TK10K13 / 1750	175	TK10K13 / 7500	750
TK10K13 / 1780	178	TK10K13 / 8000	800
TK10K13 / 1880	188	TK10K13 / 9000	900
TK10K13 / 1960	196		
TK10K13 / 2250	225		
TK10K13 / 2360	236		
TK10K13 / 2500	250		
TK10K13 / 2650	265		
TK10K13 / 2800	280		
TK10K13 / 3000	300		
TK10K13 / 3100	310		

current maximum manufacturing length:

TK10K13 / 20000 2000

Preferred belt width

b [mm]: 50

In-between widths upon request

Order example:

BRECOFLEX®-TIMING BELT 50 TK10K13 / 2500

Belt width in mm _____
 Type / Pitch _____
 Belt length in mm _____

Technical data of the BRECOFLEX® TIMING BELT

TK 10 K13

Belt width b[cm]

$$b = \frac{F_U}{z_e \cdot F_{U\text{spec}}} \quad F_U [\text{N}]$$

$$b = \frac{100 \cdot M}{z_1 \cdot z_e \cdot M_{\text{spec}}} \quad M [\text{Nm}]$$

$$b = \frac{1000 \cdot P}{z_1 \cdot z_e \cdot P_{\text{spec}}} \quad P [\text{kW}]$$

Drive load bearing characteristics

with given belt width [cm]

$$F_U = F_{U\text{spec}} \cdot z_e \cdot b \quad [\text{N}]$$

$$M = \frac{M_{\text{spec}} \cdot z_1 \cdot z_e \cdot b}{100} \quad [\text{Nm}]$$

$$P = \frac{P_{\text{spec}} \cdot z_1 \cdot z_e \cdot b}{1000} \quad [\text{kW}]$$

intermeshing number of teeth

$$z_{\text{emax}} = 12$$

$$z_e = \frac{z_1}{180} \cdot \arccos \frac{t \cdot (z_2 - z_1)}{2\pi \cdot a}$$

1. Tooth shear strength (specific belt tooth load bearing)



R.p.m. n [rpm]	F _{U spec} [N/cm]	M _{spec} [Ncm/cm]	P _{spec} [W/cm]	R.p.m. n [rpm]	F _{U spec} [N/cm]	M _{spec} [Ncm/cm]	P _{spec} [W/cm]
0	50,5	8,04	0,000	2800	22,70	3,620	10,60
20	49,0	7,80	0,163	3000	22,20	3,530	11,08
40	47,7	7,60	0,318	3200	21,70	3,450	11,55
60	46,6	7,42	0,466	3400	21,20	3,360	11,99
80	45,7	7,27	0,609	3600	20,70	3,300	12,42
100	44,8	7,13	0,746	3800	20,30	3,230	12,84
200	41,4	6,60	1,381	4000	19,86	3,160	13,24
300	39,1	6,22	1,953	4500	18,91	3,010	14,18
400	37,2	5,92	2,480	5000	18,06	2,870	15,05
500	35,7	5,68	2,980	5500	17,28	2,750	15,84
600	34,4	5,48	3,440	6000	16,58	2,640	16,58
700	33,3	5,31	3,890	6500	15,93	2,540	17,26
800	32,4	5,15	4,320	7000	15,33	2,440	17,88
900	31,5	5,01	4,730	7500	14,76	2,350	18,46
1000	30,7	4,89	5,120	8000	14,24	2,270	18,99
1100	30,0	4,77	5,500	8500	13,74	2,180	19,47
1200	29,3	4,67	5,870	9000	13,28	2,110	19,92
1300	28,7	4,57	6,220	9500	12,84	2,040	20,30
1400	28,2	4,48	6,570	10000	12,42	1,976	20,70
1500	27,6	4,40	6,910				
1600	27,1	4,32	7,230				
1700	26,7	4,24	7,550				
1800	26,2	4,17	7,860				
1900	25,8	4,10	8,160				
2000	25,4	4,04	8,460				
2200	24,6	3,92	9,030				
2400	23,9	3,81	9,580				
2600	23,3	3,71	10,100				

Rotational speeds over 10000 rpm and/ or belt speeds over 80 m/s are in need of a special drive design. Please request for our advice.

2. Tension cord strength (permitted tensile force of the belt F_{adm}), belt weight

Belt width	b	[mm]	50
BRECOFLEX®	F _{adm}	[N]	3800
Belt weight	TK10K13	[kg/m]	0,283

3. Flexibility (Minimum numbers of teeth, minimum diameter)

Drive type	BFX TK 10 K13		
without contraflexure	Synchronising pulley	z _{min}	25
	Tension roller (smooth), running on teeth	d _{min} [mm]	80
with contraflexure	Synchronising pulley	z _{min}	25
	Tension roller (smooth), running on the back of the belt	d _{min} [mm]	120

T standard timing belts - endless

SYNCHROFLEX® TIMING BELT (SFX)

T 2

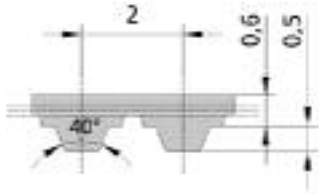

Standard T profile with metric pitch and trapezoidal teeth.

The technical data refer to standard casting polyurethane and standard steel cord tension members.

Available versions:

- single-sided
- with Aramid tension member
- Polyurethane special materials upon request
- antistatic, coloured, mechanical reworked
- **FA:** with reinforced back of the belt

Type / Length	Number of teeth	Type / Length	Number of teeth
T 2 / 90	45	T 2 / 256	128
T 2 / 108	54	T 2 / 262	131
T 2 / 118	59	T 2 / 280	140
T 2 / 120 FA	60	T 2 / 292	146
T 2 / 120	60	T 2 / 320	160
T 2 / 138	69	T 2 / 360	180
T 2 / 140	70	T 2 / 600	300
T 2 / 144	72	T 2 / 710	355
T 2 / 150	75	T 2 / 710 FA	355
T 2 / 160	80		
T 2 / 180	90		
T 2 / 200	100		
T 2 / 220 FA	110		
T 2 / 220	110		
T 2 / 240	120		

Preferred belt width b [mm]: 4 6 10
 In-between widths and larger widths are available.

Other dimension upon request.

Order example:

SYNCHROFLEX®-ZAHNRIEMEN 6 T2 / 240

Belt width in mm _____

Type / Pitch _____

Belt length in mm _____

Technical data of the SYNCHROFLEX® TIMING BELT

T 2

Belt width b[cm]

$$b = \frac{F_U}{z_e \cdot F_{Uspec}} \quad F_U [N]$$

$$b = \frac{100 \cdot M}{z_1 \cdot z_e \cdot M_{spec}} \quad M [Nm]$$

$$b = \frac{1000 \cdot P}{z_1 \cdot z_e \cdot P_{spec}} \quad P [kW]$$

Drive load bearing characteristics
with given belt width [cm]

$$F_U = F_{Uspec} \cdot z_e \cdot b \quad [N]$$

$$M = \frac{M_{spec} \cdot z_1 \cdot z_e \cdot b}{100} \quad [Nm]$$

$$P = \frac{P_{spec} \cdot z_1 \cdot z_e \cdot b}{1000} \quad [kW]$$

intermeshing number of teeth

$$z_{e,max} = 12$$

$$z_e = \frac{z_1}{180} \cdot \arccos \frac{t \cdot (z_2 - z_1)}{2\pi \cdot a}$$



1. Tooth shear strength (specific belt tooth load bearing)

R.p.m. n [rpm]	F _{Uspec} [N/cm]	M _{spec} [Ncm/cm]	P _{spec} [W/cm]	R.p.m. n [rpm]	F _{Uspec} [N/cm]	M _{spec} [Ncm/cm]	P _{spec} [W/cm]
0	6,58	0,209	0,000	2200	3,50	0,111	0,257
20	6,36	0,202	0,004	2400	3,42	0,109	0,274
40	6,18	0,197	0,008	2500	3,39	0,108	0,282
60	6,03	0,192	0,012	2600	3,35	0,107	0,290
80	5,90	0,188	0,016	2800	3,29	0,105	0,307
100	5,79	0,184	0,019	2880	3,26	0,104	0,313
150	5,56	0,177	0,028	3000	3,23	0,103	0,323
200	5,38	0,171	0,036	3200	3,17	0,101	0,338
300	5,10	0,162	0,051	3400	3,12	0,099	0,354
400	4,89	0,156	0,065	3600	3,07	0,098	0,368
500	4,72	0,150	0,079	3800	3,02	0,096	0,383
600	4,58	0,146	0,092	4000	2,98	0,095	0,397
700	4,45	0,142	0,104	4500	2,88	0,092	0,432
730	4,42	0,141	0,108	5000	2,78	0,088	0,463
800	4,35	0,138	0,116	5500	2,70	0,086	0,495
900	4,25	0,135	0,127	6000	2,63	0,084	0,526
1000	4,16	0,132	0,139	6500	2,56	0,081	0,555
1100	4,08	0,130	0,150	7000	2,49	0,079	0,581
1200	4,01	0,128	0,160	7500	2,43	0,077	0,607
1300	3,94	0,125	0,171	8000	2,37	0,075	0,632
1400	3,88	0,124	0,181	8500	2,32	0,074	0,657
1460	3,85	0,123	0,187	9000	2,27	0,072	0,681
1500	3,82	0,122	0,191	9500	2,22	0,071	0,703
1600	3,77	0,120	0,201	10000	2,18	0,069	0,727
1700	3,72	0,118	0,211	12000	2,02	0,064	0,808
1800	3,67	0,117	0,220	15000	1,82	0,058	0,910
1900	3,62	0,115	0,229	18000	1,66	0,053	0,996
2000	3,58	0,114	0,239	20000	1,57	0,050	1,047

2. Tension cord strength (permitted tensile force of the belt F_{adm}), belt weight

Belt width	b [mm]	4	6	10	16	25	32
SYNCHROFLEX® T2	F _{adm} [N]	39	65	117	195	312	403
Belt weight	T2 [kg/m]	0,004	0,007	0,011	0,018	0,028	0,035

3. Flexibility (Minimum numbers of teeth, minimum diameter)

Drive type	SFX T2		
without contraflexure	Synchronising pulley	z _{min}	10
	Tension roller (smooth), running on teeth	d _{min} [mm]	15
with contraflexure	Synchronising pulley	z _{min}	18
	Tension roller (smooth), running on the back of the belt	d _{min} [mm]	15

T standard timing belts - endless

SYNCHROFLEX[®] TIMING BELT (SFX)

T 2,5

T 2,5-DL

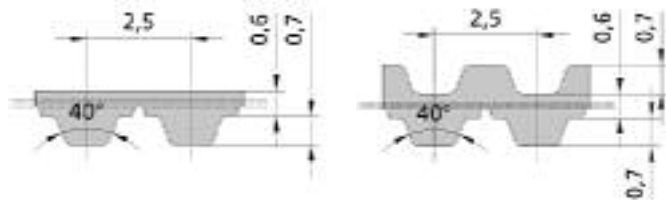

Standard T profile according to DIN 7721 with metric pitch and trapezoidal teeth.

The technical data refer to standard casting polyurethane and standard steel cord tension members.

Available versions:

- single-sided (as standard)
- with Aramid tension member
- Polyurethane special materials upon request
- antistatic, coloured, mechanical reworked
- **DL:** double-sided
- **FA:** with reinforced back of the belt
- **FN:** with profiles on the back of the belt

Type / Length	Number of teeth	Type / Length	Number of teeth
T 2,5 / 55	FA 22	T 2,5 / 380	152
T 2,5 / 120	48	T 2,5 / 395	158
T 2,5 / 145	58	T 2,5 / 400	FA 160
T 2,5 / 160	4	T 2,5 / 415	DL 166
T 2,5 / 160	FA 64	T 2,5 / 420	168
T 2,5 / 177,5	71	T 2,5 / 457,5	DL 183
T 2,5 / 180	72	T 2,5 / 480	192
T 2,5 / 182,5	73	T 2,5 / 500	200
T 2,5 / 200	80	T 2,5 / 540	216
T 2,5 / 210	FA 84	T 2,5 / 540	FA 216
T 2,5 / 220	FN 88	T 2,5 / 600	FA 240
T 2,5 / 225	90	T 2,5 / 620	248
T 2,5 / 230	92	T 2,5 / 650	260
T 2,5 / 230	FA 92	T 2,5 / 780	312
T 2,5 / 245	98	T 2,5 / 950	380
T 2,5 / 250	100	T 2,5 / 1300	520
T 2,5 / 265	106	T 2,5 / 1300	FA 520
T 2,5 / 285	114	T 2,5 / 1475	FA 590
T 2,5 / 285	FA 114		
T 2,5 / 290	116		
T 2,5 / 305	122		
T 2,5 / 305	FA 122		
T 2,5 / 317,5	127		
T 2,5 / 317,5	DL 127		
T 2,5 / 330	132		

Preferred belt length mm 4 6 10
In-between widths and larger widths are available.

Other dimension upon request.

Order example:

SYNCHROFLEX[®]-TIMING BELT 10 T 2,5 / 380

Belt width in mm _____

Type / Pitch _____

Belt length in mm _____

Technical data of the SYNCHROFLEX® TIMING BELT

T 2,5

Belt width b[cm]

$$b = \frac{F_U}{z_e \cdot F_{U\text{spec}}} \quad F_U [\text{N}]$$

$$b = \frac{100 \cdot M}{z_1 \cdot z_e \cdot M_{\text{spec}}} \quad M [\text{Nm}]$$

$$b = \frac{1000 \cdot P}{z_1 \cdot z_e \cdot P_{\text{spec}}} \quad P [\text{kW}]$$

Drive load bearing characteristics with given belt width [cm]

$$F_U = F_{U\text{spec}} \cdot z_e \cdot b \quad [\text{N}]$$

$$M = \frac{M_{\text{spec}} \cdot z_1 \cdot z_e \cdot b}{100} \quad [\text{Nm}]$$

$$P = \frac{P_{\text{spec}} \cdot z_1 \cdot z_e \cdot b}{1000} \quad [\text{kW}]$$

intermeshing number of teeth

$$z_{\text{emax}} = 12$$

$$z_e = \frac{z_1}{180} \cdot \arccos \frac{t \cdot (z_2 - z_1)}{2\pi \cdot a}$$



1. Tooth shear strength (specific belt tooth load bearing)

R.p.m. n [rpm]	F _{U spec} [N/cm]	M _{spec} [Ncm/cm]	P _{spec} [W/cm]	R.p.m. n [rpm]	F _{U spec} [N/cm]	M _{spec} [Ncm/cm]	P _{spec} [W/cm]
0	9,03	0,359	0,000	2200	4,80	0,191	0,440
20	8,72	0,347	0,007	2400	4,70	0,187	0,470
40	8,48	0,337	0,014	2500	4,65	0,185	0,484
60	8,28	0,329	0,021	2600	4,60	0,183	0,499
80	8,10	0,322	0,027	2800	4,51	0,180	0,527
100	7,95	0,316	0,033	2880	4,48	0,178	0,538
150	7,64	0,304	0,048	3000	4,43	0,176	0,554
200	7,39	0,294	0,062	3200	4,36	0,173	0,581
300	7,01	0,279	0,088	3400	4,28	0,170	0,607
400	6,71	0,267	0,112	3600	4,22	0,168	0,632
500	6,48	0,258	0,135	3800	4,15	0,165	0,657
600	6,28	0,250	0,157	4000	4,09	0,163	0,682
700	6,11	0,243	0,178	4500	3,95	0,157	0,740
730	6,07	0,241	0,185	5000	3,82	0,152	0,796
800	5,97	0,237	0,199	5500	3,71	0,148	0,850
900	5,83	0,232	0,219	6000	3,60	0,143	0,901
1000	5,71	0,227	0,238	6500	3,51	0,140	0,950
1100	5,61	0,223	0,257	7000	3,42	0,136	0,997
1200	5,51	0,219	0,275	7500	3,33	0,133	1,042
1300	5,41	0,215	0,293	8000	3,26	0,130	1,086
1400	5,33	0,212	0,311	8500	3,18	0,127	1,128
1460	5,28	0,210	0,321	9000	3,11	0,124	1,168
1500	5,25	0,209	0,328	9500	3,05	0,121	1,207
1600	5,17	0,206	0,345	10000	2,99	0,119	1,245
1700	5,10	0,203	0,361	12000	2,77	0,110	1,384
1800	5,04	0,200	0,378	15000	2,50	0,099	1,561
1900	4,97	0,198	0,394	18000	2,28	0,091	1,708
2000	4,91	0,195	0,409	20000	2,15	0,086	1,791

2. Tension cord strength (permitted tensile force of the belt F_{adm}), belt weight

Belt width	b	[mm]	4	6	10	16	25	32
SYNCHROFLEX®	F _{adm}	[N]	39	65	117	195	312	403
Belt weight	T 2.5	[kg/m]	0,006	0,009	0,015	0,024	0,038	0,048
	T 2.5 DL	[kg/m]	0,006	0,009	0,016	0,025	0,040	0,051

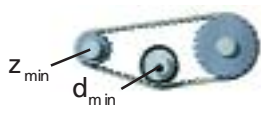
3. Flexibility (Minimum numbers of teeth, minimum diameter)

Drive type	SFX T 2,5		
without contraflexure	Synchronising pulley	z _{min}	10
	Tension roller (smooth), running on teeth	d _{min} [mm]	15
with contraflexure	Synchronising pulley	z _{min}	18
	Tension roller (smooth), running on the back of the belt	d _{min} [mm]	15

T standard timing belts - endless

SYNCHROFLEX® TIMING BELT (SFX)

T 5

T 5-DL

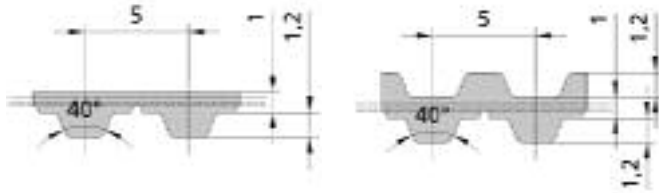

Standard T profile according to DIN 7721 with metric pitch and trapezoidal teeth.

The technical data refer to standard casting polyurethane and standard steel cord tension members.

Available versions:

- single-sided (as standard)
- with E tension member for a better flexibility
- with Aramid tension member
- Polyurethane special materials upon request
- antistatic, coloured, mechanical reworked
- **DL:** double-sided
- **FA:** with reinforced back of the belt
- **FN:** with profiles on the back of the belt

Order example:

SYNCHROFLEX®-TIMING BELT

10 T5 / 455

Belt width in mm _____
Type / Pitch _____
Belt length in mm _____

Type / length	Number of teeth	Type / length	Number of teeth
T 5/ 100	20	T 5/ 590 DL	118
T 5/ 150	30	T 5/ 600 FN	120
T 5/ 150 DL	30	T 5/ 610	122
T 5/ 165	33	T 5/ 615 FN	123
T 5/ 180	36	T 5/ 620	124
T 5/ 185	37	T 5/ 620 DL	124
T 5/ 200	40	T 5/ 625 DL	125
T 5/ 210	42	T 5/ 630	126
T 5/ 215	43	T 5/ 630 FA	126
T 5/ 220	44	T 5/ 650	130
T 5/ 225	45	T 5/ 660 FN	132
T 5/ 245	49	T 5/ 690	138
T 5/ 250	50	T 5/ 690 FA	138
T 5/ 255	51	T 5/ 700	140
T 5/ 260	52	T 5/ 720	144
T 5/ 260 DL	52	T 5/ 725	145
T 5/ 270	54	T 5/ 750	150
T 5/ 280	56	T 5/ 750 DL	150
T 5/ 295	59	T 5/ 765	153
T 5/ 300 DL	60	T 5/ 780	156
T 5/ 305	61	T 5/ 800	160
T 5/ 330	66	T 5/ 815	163
T 5/ 340	68	T 5/ 815 DL	163
T 5/ 355	71	T 5/ 840	168
T 5/ 365	73	T 5/ 860 DL	172
T 5/ 390	78	T 5/ 860 FN	172
T 5/ 400	80	T 5/ 900	180
T 5/ 410	82	T 5/ 920	184
T 5/ 410 DL	82	T 5/ 925	185
T 5/ 420	84	T 5/ 940	188
T 5/ 455	91	T 5/ 940 DL	188
T 5/ 460	92	T 5/ 990	198
T 5/ 460 DL	92	T 5/1075	215
T 5/ 480	96	T 5/1075 FA	215
T 5/ 500	100	T 5/1100	220
T 5/ 505	101	T 5/1100 DL	220
T 5/ 510	102	T 5/1140 FN	228
T 5/ 515 DL	103	T 5/1160	232
T 5/ 525	105	T 5/1215	243
T 5/ 525 DL	105	T 5/1315	263
T 5/ 545	109	T 5/1325 DL	265
T 5/ 550	110	T 5/1380	276
T 5/ 560	112	T 5/1500	300
T 5/ 575	115		
T 5/ 590	118		

Preferred belt length mm 6 10 16 25 50

In-between widths and larger widths are available.
Other dimension upon request.

Technical data of the SYNCHROFLEX® TIMING BELT

T 5, T 5-DL

Belt width b[cm]

$$b = \frac{F_U}{z_e \cdot F_{U\text{spec}}} \quad F_U [\text{N}]$$

$$b = \frac{100 \cdot M}{z_1 \cdot z_e \cdot M_{\text{spec}}} \quad M [\text{Nm}]$$

$$b = \frac{1000 \cdot P}{z_1 \cdot z_e \cdot P_{\text{spec}}} \quad P [\text{kW}]$$

Drive load bearing characteristics

with given belt width [cm]

$$F_U = F_{U\text{spec}} \cdot z_e \cdot b \quad [\text{N}]$$

$$M = \frac{M_{\text{spec}} \cdot z_1 \cdot z_e \cdot b}{100} \quad [\text{Nm}]$$

$$P = \frac{P_{\text{spec}} \cdot z_1 \cdot z_e \cdot b}{1000} \quad [\text{kW}]$$

intermeshing number of teeth

$$z_{\text{emax}} = 12$$

$$z_e = \frac{z_1}{180} \cdot \arccos \frac{t \cdot (z_2 - z_1)}{2\pi \cdot a}$$

1. Tooth shear strength (specific belt tooth load bearing)

R.p.m. n [rpm]	F _{U spec} [N/cm]	M _{spec} [Ncm/cm]	P _{spec} [W/cm]	R.p.m. n [rpm]	F _{U spec} [N/cm]	M _{spec} [Ncm/cm]	P _{spec} [W/cm]
0	24,00	1,910	0,000	2800	12,59	1,002	2,94
20	23,40	1,861	0,039	3000	12,37	0,984	3,09
40	22,90	1,819	0,076	3200	12,16	0,967	3,24
60	22,40	1,783	0,112	3400	11,96	0,951	3,39
80	22,00	1,751	0,147	3600	11,77	0,936	3,53
100	21,70	1,723	0,180	3800	11,59	0,922	3,67
200	20,30	1,614	0,338	4000	11,42	0,909	3,81
300	19,30	1,536	0,483	4500	11,03	0,878	4,14
400	18,55	1,476	0,618	5000	10,68	0,850	4,45
500	17,93	1,427	0,747	5500	10,36	0,825	4,75
600	17,41	1,385	0,870	6000	10,07	0,802	5,04
700	16,96	1,349	0,989	6500	9,81	0,780	5,31
800	16,56	1,318	1,104	7000	9,56	0,761	5,58
900	16,20	1,289	1,215	7500	9,33	0,742	5,83
1000	15,88	1,263	1,323	8000	9,11	0,725	6,08
1100	15,58	1,240	1,428	8500	8,91	0,709	6,31
1200	15,31	1,218	1,531	9000	8,72	0,694	6,54
1300	15,06	1,198	1,632	9500	8,54	0,679	6,76
1400	14,83	1,180	1,730	10000	8,37	0,666	6,97
1500	14,61	1,162	1,826				
1600	14,40	1,146	1,920				
1700	14,21	1,131	2,010				
1800	14,03	1,116	2,100				
1900	13,85	1,102	2,190				
2000	13,69	1,089	2,280				
2200	13,38	1,065	2,450				
2400	13,10	1,042	2,620				
2600	12,84	1,021	2,780				

Rotational speeds over 10000 rpm and/or belt speeds over 80 m/s are in need of a special drive design. Please request for our advice.

2. Tension cord strength (permitted tensile force of the belt F_{adm}), belt weight

Belt width	b [mm]	6	10	16	25	32	50	75	100
SYNCHROFLEX® F _{adm} [N]		180	330	570	930	1200	1920	2940	3930
Belt weight T5 [kg/m]		0,014	0,024	0,038	0,060	0,077	0,120	0,180	0,240
T5-DL [kg/m]		0,016	0,027	0,043	0,067	0,086	0,135	0,203	0,270

3. Flexibility (Minimum numbers of teeth, minimum diameter)

Drive type	SFX T 5		
without contraflexure	Synchronising pulley	z _{min}	10
	Tension roller (smooth), running on teeth	d _{min} [mm]	30
with contraflexure	Synchronising pulley	z _{min}	15
	Tension roller (smooth), running on the back of the belt	d _{min} [mm]	30

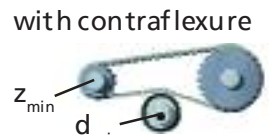
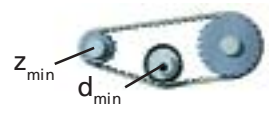

T standard timing belts - endless

BRECOFLEX®-ZAHNRIEMEN (BFX)

T 5

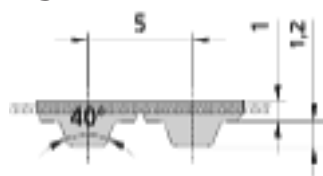

T 5-DL

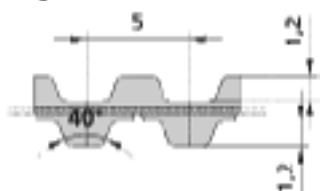

T 5-DR

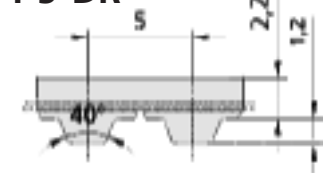

Available endless lengths for T 5

- Preferred lengths refer to table
- under 1075 mm: Further lengths on request
- Belt length smaller than 1075 mm with nylon tooth facing
- over 1075 mm: Any number of teeth available, request minimum purchase amount for in-between lengths
- over 15,000 mm on request

Available versions:

- **T 5:** Standard, single-sided
- **E:** with E tension member
- **DL:** Standard, double-sided, available length: over 1075 mm. Lengths over 2650 mm, request minimum purchase amount, under 1075 mm upon request.
- **PAZ:** Nylon tooth facing
- **DL-PAZ:** Nylon facing on double-sided belts, coating is only possible on the inner side. Request minimum purchase amount for lengths over 2650 mm
- **DR, DR-PAZ:** Reinforced back of the belt, through 1.2 mm larger belt thickness, available in lengths over 1075 mm, minimum purchase amount on request

Order example:

BRECOFLEX®-TIMING BELT

10 T5 / 2000

Belt width in mm _____

Type / Pitch _____

Belt length in mm _____

100

Endless lengths			
Type / length	Number of teeth	Type / length	Number of teeth
T 5/ 200	40	T 5/ 850	170
T 5/ 215	43	T 5/ 860	172
T 5/ 220	44	T 5/ 900	180
T 5/ 225	45	T 5/ 945	189
T 5/ 240	48	T 5/ 990	198
T 5/ 245	49	T 5/ 1040	208
T 5/ 255	51	T 5/ 1075	215
T 5/ 260	52	T 5/ 1100	220
T 5/ 270	54	T 5/ 1215	243
T 5/ 280	56	T 5/ 1380	276
T 5/ 295	59	T 5/ 1400	280
T 5/ 305	61	T 5/ 1500	300
T 5/ 330	66	T 5/ 1600	320
T 5/ 340	68	T 5/ 1700	340
T 5/ 355	71	T 5/ 1800	360
T 5/ 365	73	T 5/ 1900	380
T 5/ 370	74	T 5/ 2000	400
T 5/ 390	78	T 5/ 2120	424
T 5/ 400	80	T 5/ 2240	448
T 5/ 410	82	T 5/ 2360	472
T 5/ 420	84	T 5/ 2500	500
T 5/ 435	87	T 5/ 2650	530
T 5/ 455	91	T 5/ 2800	560
T 5/ 480	96	T 5/ 3000	600
T 5/ 500	100	T 5/ 3150	630
T 5/ 510	102	T 5/ 3350	670
T 5/ 525	105	T 5/ 3550	710
T 5/ 545	109	T 5/ 3750	750
T 5/ 560	112	T 5/ 4000	800
T 5/ 575	115	T 5/ 4250	850
T 5/ 610	122	T 5/ 4500	900
T 5/ 620	124	T 5/ 4750	950
T 5/ 630	126	T 5/ 5000	1000
T 5/ 660	132	T 5/ 5300	1060
T 5/ 690	138	T 5/ 5600	1120
T 5/ 720	144	T 5/ 6000	1200
T 5/ 750	150	T 5/ 6300	1260
T 5/ 755	151	T 5/ 6700	1340
T 5/ 780	156	T 5/ 7100	1420
T 5/ 800	160	T 5/ 7500	1500
T 5/ 815	163	current maximum	
T 5/ 840	168	manufacturing length:	
		T 5/15000	3000

Preferred belt length mm 10 16 25 32 50 75 100
In-between belt widths are available

Technical data of the BRECOFLEX® TIMING BELT

T 5, T 5-DL, T 5-DR

Belt width b[cm]

$$b = \frac{F_U}{z_e \cdot F_{U\text{spec}}} \quad F_U [\text{N}]$$

$$b = \frac{100 \cdot M}{z_1 \cdot z_e \cdot M_{\text{spec}}} \quad M [\text{Nm}]$$

$$b = \frac{1000 \cdot P}{z_1 \cdot z_e \cdot P_{\text{spec}}} \quad P [\text{kW}]$$

Drive load bearing characteristics
with given belt width [cm]

$$F_U = F_{U\text{spec}} \cdot z_e \cdot b \quad [\text{N}]$$

$$M = \frac{M_{\text{spec}} \cdot z_1 \cdot z_e \cdot b}{100} \quad [\text{Nm}]$$

$$P = \frac{P_{\text{spec}} \cdot z_1 \cdot z_e \cdot b}{1000} \quad [\text{kW}]$$

intermeshing number of teeth

$$z_{\text{emax}} = 12$$

$$z_e = \frac{z_1}{180} \cdot \arccos \frac{t \cdot (z_2 - z_1)}{2\pi \cdot a}$$

1. Tooth shear strength (specific belt tooth load bearing)



R.p.m. n [rpm]	$F_{U\text{spec}}$ [N/cm]	M_{spec} [Ncm/cm]	P_{spec} [W/cm]	R.p.m. n [rpm]	$F_{U\text{spec}}$ [N/cm]	M_{spec} [Ncm/cm]	P_{spec} [W/cm]
0	24,00	1,910	0,000	2800	12,59	1,002	2,94
20	23,40	1,861	0,039	3000	12,37	0,984	3,09
40	22,90	1,819	0,076	3200	12,16	0,967	3,24
60	22,40	1,783	0,112	3400	11,96	0,951	3,39
80	22,00	1,751	0,147	3600	11,77	0,936	3,53
100	21,70	1,723	0,180	3800	11,59	0,922	3,67
200	20,30	1,614	0,338	4000	11,42	0,909	3,81
300	19,30	1,536	0,483	4500	11,03	0,878	4,14
400	18,55	1,476	0,618	5000	10,68	0,850	4,45
500	17,93	1,427	0,747	5500	10,36	0,825	4,75
600	17,41	1,385	0,870	6000	10,07	0,802	5,04
700	16,96	1,349	0,989	6500	9,81	0,780	5,31
800	16,56	1,318	1,104	7000	9,56	0,761	5,58
900	16,20	1,289	1,215	7500	9,33	0,742	5,83
1000	15,88	1,263	1,323	8000	9,11	0,725	6,08
1100	15,58	1,240	1,428	8500	8,91	0,709	6,31
1200	15,31	1,218	1,531	9000	8,72	0,694	6,54
1300	15,06	1,198	1,632	9500	8,54	0,679	6,76
1400	14,83	1,180	1,730	10000	8,37	0,666	6,97
1500	14,61	1,162	1,826				
1600	14,40	1,146	1,920				
1700	14,21	1,131	2,010				
1800	14,03	1,116	2,100				
1900	13,85	1,102	2,190				
2000	13,69	1,089	2,280				
2200	13,38	1,065	2,450				
2400	13,10	1,042	2,620				
2600	12,84	1,021	2,780				

Rotational speeds over 10000 rpm and/or belt speeds over 80 m/s are in need of a special drive design. Please request for our advice.

2. Tension cord strength (permitted tensile force of the belt F_{adm}), belt weight

Belt width	b	[mm]	6	10	16	25	32	50	75	100
BRECOFLEX®	F_{adm}	[N]	180	330	570	930	1200	1920	2940	3930
Belt weight	T5	[kg/m]	0,013	0,022	0,034	0,052	0,067	0,105	0,163	0,210
	T5-DL	[kg/m]	0,017	0,028	0,045	0,072	0,099	0,141	0,212	0,283
	T5-DR	[kg/m]	0,021	0,036	0,057	0,090	0,115	0,180	0,271	0,362

3. Flexibility (Minimum numbers of teeth, minimum diameter)

Drive type		BFX T 5	BFX T5-E	BFX T5-DL	BFX T5-DL-E	BFX T5-DR
without contraflexure 	Synchronising pulley z_{min}	10	10	15	12	20*
	Tension roller (smooth), running on teeth d_{min} [mm]	30	30	30	30	30
with contraflexure 	Synchronising pulley z_{min}	15	12	15	12	20*
	Tension roller (smooth), running on the back of the belt d_{min} [mm]	30	30	30	30	60

*Rotational speed limitation

T standard timing belts - endless

SYNCHROFLEX® TIMING BELT (SFX)

T 10

T 10-DL

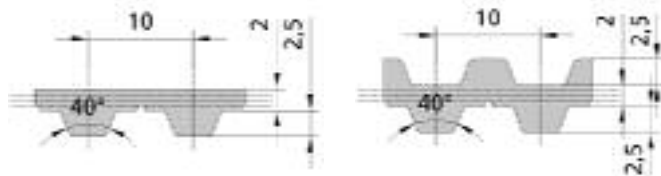

Standard T profile according to DIN 7721 with metric pitch and trapezoidal teeth.

The technical data refer to standard casting polyurethane and standard steel cord tension members.

Available versions:

- **T 10:** single-sided (as standard)
- with E tension member for a better flexibility
- with Aramid tension member
- Polyurethane special materials upon request
- antistatic, coloured, mechanical reworked
- **DL:** double-sided
- **FA:** with reinforced back of the belt
- **FN:** with profiles on the back of the belt

Type / length	Number of teeth	Type / length	Number of teeth
T 10/ 260	26	T 10/ 980 DL	98
T 10/ 260 DL	26	T 10/ 1010	101
T 10/ 350	35	T 10/ 1080	108
T 10/ 370	37	T 10/ 1110	111
T 10/ 410	41	T 10/ 1140	114
T 10/ 410 FA	41	T 10/ 1150	115
T 10/ 410	41	T 10/ 1210	121
T 10/ 420 FN	42	T 10/ 1210 DL	121
T 10/ 440	44	T 10/ 1240	124
T 10/ 450	45	T 10/ 1240 DL	124
T 10/ 500	50	T 10/ 1250	125
T 10/ 530 DL	53	T 10/ 1250 DL	125
T 10/ 530	53	T 10/ 1300	130
T 10/ 560	56	T 10/ 1320	132
T 10/ 600	60	T 10/ 1320 DL	132
T 10/ 610	61	T 10/ 1350	135
T 10/ 630 DL	63	T 10/ 1350 DL	135
T 10/ 630	63	T 10/ 1390	139
T 10/ 660 DL	66	T 10/ 1400	140
T 10/ 660	65	T 10/ 1420	142
T 10/ 680	68	T 10/ 1420 DL	142
T 10/ 690	69	T 10/ 1450	145
T 10/ 700	70	T 10/ 1460	146
T 10/ 720 DL	72	T 10/ 1500	150
T 10/ 720	72	T 10/ 1560	156
T 10/ 730	73	T 10/ 1610	161
T 10/ 750	75	T 10/ 1610 DL	161
T 10/ 760	76	T 10/ 1750	175
T 10/ 780	78	T 10/ 1780	178
T 10/ 800 FN	80	T 10/ 1800 FN	180
T 10/ 810	81	T 10/ 1880 DL	188
T 10/ 840 DL	84	T 10/ 1880	188
T 10/ 840	84	T 10/ 1960	196
T 10/ 850	85	T 10/ 2250	225
T 10/ 880	88	T 10/ 3100	310
T 10/ 890	89	T 10/ 4780	478
T 10/ 920	92	T 10/ 4780 DL*	478
T 10/ 960	96		
T 10/ 970	97		
T 10/ 980	98		

Order example:

SYNCHROFLEX®-TIMING BELT

16 T10 / 260

Belt width in mm _____

Type / Pitch _____

Belt length in mm _____

*Request application-dependent information

Preferred belt length mm 16 25 32 50
In-between widths and larger widths are available.

Other dimension upon request.

Technical data of the SYNCHROFLEX® TIMING BELT

T 10, T 10-DL

Belt width b[cm]

$$b = \frac{F_U}{z_e \cdot F_{U\text{spec}}} \quad F_U [\text{N}]$$

$$b = \frac{100 \cdot M}{z_1 \cdot z_e \cdot M_{\text{spec}}} \quad M [\text{Nm}]$$

$$b = \frac{1000 \cdot P}{z_1 \cdot z_e \cdot P_{\text{spec}}} \quad P [\text{kW}]$$

Drive load bearing characteristics

with given belt width [cm]

$$F_U = F_{U\text{spec}} \cdot z_e \cdot b \quad [\text{N}]$$

$$M = \frac{M_{\text{spec}} \cdot z_1 \cdot z_e \cdot b}{100} \quad [\text{Nm}]$$

$$P = \frac{P_{\text{spec}} \cdot z_1 \cdot z_e \cdot b}{1000} \quad [\text{kW}]$$

intermeshing number of teeth

$$z_{\text{emax}} = 12$$

$$z_e = \frac{z_1}{180} \cdot \arccos \frac{t \cdot (z_2 - z_1)}{2\pi \cdot a}$$

1. Tooth shear strength (specific belt tooth load bearing)

R.p.m. n [rpm]	F _{U spec} [N/cm]	M _{spec} [Ncm/cm]	P _{spec} [W/cm]	R.p.m. n [rpm]	F _{U spec} [N/cm]	M _{spec} [Ncm/cm]	P _{spec} [W/cm]
0	50,5	8,04	0,000	2800	22,70	3,62	10,60
20	49,0	7,80	0,163	3000	22,20	3,53	11,08
40	47,7	7,60	0,318	3200	21,70	3,45	11,55
60	46,6	7,42	0,466	3400	21,20	3,36	11,99
80	45,7	7,27	0,609	3600	20,70	3,30	12,42
100	44,8	7,13	0,746	3800	20,30	3,23	12,84
200	41,4	6,60	1,381	4000	19,86	3,16	13,24
300	39,1	6,22	1,953	4500	18,91	3,01	14,18
400	37,2	5,92	2,480	5000	18,06	2,87	15,05
500	35,7	5,68	2,980	5500	17,28	2,75	15,84
600	34,4	5,48	3,440	6000	16,58	2,64	16,58
700	33,3	5,31	3,890	6500	15,93	2,54	17,26
800	32,4	5,15	4,320	7000	15,33	2,44	17,88
900	31,5	5,01	4,730	7500	14,76	2,35	18,46
1000	30,7	4,89	5,120	8000	14,24	2,27	18,99
1100	30,0	4,77	5,500	8500	13,74	2,18	19,47
1200	29,3	4,67	5,870	9000	13,28	2,11	19,92
1300	28,7	4,57	6,220	9500	12,84	2,04	20,30
1400	28,2	4,48	6,570	10000	12,42	1,97	20,70
1500	27,6	4,40	6,910				
1600	27,1	4,32	7,230				
1700	26,7	4,24	7,550				
1800	26,2	4,17	7,860				
1900	25,8	4,10	8,160				
2000	25,4	4,04	8,460				
2200	24,6	3,92	9,030				
2400	23,9	3,81	9,580				
2600	23,3	3,71	10,100				

Rotational speeds over 10000 rpm and/or belt speeds over 60 m/s are in need of a special drive design. Please request for our advice.

2. Tension cord strength (permitted tensile force of the belt F_{adm}), belt weight

Belt width	b	[mm]	16	25	32	50	75	100	150
SYNCHROFLEX®	F _{adm}	[N]	1200	2000	2700	4300	6600	8800	13400
Belt weight	T 10	[kg/m]	0,077	0,120	0,154	0,240	0,360	0,480	0,720
	T 10 DL	[kg/m]	0,091	0,143	0,182	0,285	0,428	0,570	0,855

3. Flexibility (Minimum numbers of teeth, minimum diameter)

Drive type	SFX T 10		
without contraflexure	Synchronising pulley	z _{min}	12
	Tension roller (smooth), running on teeth	d _{min} [mm]	60
with contraflexure	Synchronising pulley	z _{min}	20
	Tension roller (smooth), running on the back of the belt	d _{min} [mm]	60

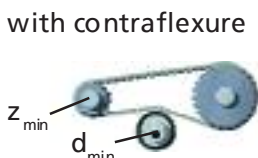

T standard timing belts - endless

BRECOFLEX® TIMING BELTS (BFX)

T 10

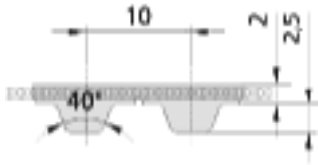

T 10-DL

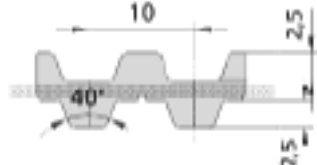

T 10-DR

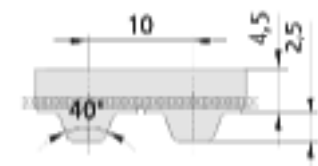

T 10-T

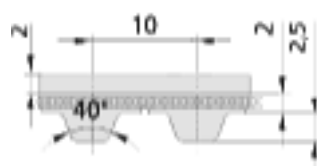

Available endless lengths for T10

- Preferred lengths refer to table
- Belt length smaller than 1080 mm with nylon tooth facing
- under 1080 mm: Further lengths on request
- over 1080 mm: Any number of teeth available, request minimum purchase amount for in-between lengths
- over 20000 mm: on request

Available versions:

- **T 10:** Standard, single-sided
- **E:** with E tension member
- **DL, DL-E:** Standard, double-sided, available length over 1080 mm, for length over 5300 mm request minimum purchase amount
- **PAZ:** Nylon tooth facing
- **DL-PAZ:** Nylon on double-sided belts, only inner side can be coated, available length over 1080 mm, for length over 5300 mm request minimum purchase amount
- **T, T-PAZ:** Transport support, available length over 1080 mm, minimum purchase amount on request
- **DR, DR-PAZ:** Reinforced back of the belt, through 2.5 mm larger belt thickness, available length over 1080 mm minimum purchase amount on request

Endless lengths

Type / length	Number of teeth	Type / length	Number of teeth
T 10 / 500	50	T 10 / 1750	175
T 10 / 530	53	T 10 / 1780	178
T 10 / 560	56	T 10 / 1880	188
T 10 / 600	60	T 10 / 1960	196
T 10 / 610	61	T 10 / 2250	225
T 10 / 630	63	T 10 / 2360	236
T 10 / 660	66	T 10 / 2500	250
T 10 / 690	69	T 10 / 2650	265
T 10 / 700	70	T 10 / 2800	280
T 10 / 720	72	T 10 / 3000	300
T 10 / 780	78	T 10 / 3100	310
T 10 / 810	81	T 10 / 3150	315
T 10 / 840	84	T 10 / 3350	335
T 10 / 880	88	T 10 / 3750	375
T 10 / 890	89	T 10 / 4000	400
T 10 / 920	92	T 10 / 4250	425
T 10 / 960	96	T 10 / 4500	450
T 10 / 970	97	T 10 / 4750	475
T 10 / 980	98	T 10 / 5000	500
T 10 / 990	99	T 10 / 5300	530
T 10 / 1010	101	T 10 / 5600	560
T 10 / 1080	108	T 10 / 6000	600
T 10 / 1150	115	T 10 / 6300	630
T 10 / 1210	121	T 10 / 6700	670
T 10 / 1240	124	T 10 / 7100	710
T 10 / 1250	125	T 10 / 7500	750
T 10 / 1320	132	T 10 / 8000	800
T 10 / 1350	135	T 10 / 9000	900
T 10 / 1390	139	current maximum manufacturing length:	
T 10 / 1400	140		
T 10 / 1420	142	T 10 / 20000	2000
T 10 / 1460	146		
T 10 / 1500	150		
T 10 / 1560	156		
T 10 / 1610	161		

Preferred belt length mm 16 25 32 50 75 100

In-between belt widths are available

Order example:

BRECOFLEX®-TIMING BELT 25 T10 / 3350 -DL-E

Belt width in mm _____

Type / Pitch _____

Belt length in mm _____

Specification _____

Technical data of the BRECOFLEX® TIMING BELT

T 10, T 10-DL, T 10-DR, T 10-T

Belt width b[cm]

$$b = \frac{F_U}{z_e \cdot F_{U\text{spec}}} \quad F_U [\text{N}]$$

$$b = \frac{100 \cdot M}{z_1 \cdot z_e \cdot M_{\text{spec}}} \quad M [\text{Nm}]$$

$$b = \frac{1000 \cdot P}{z_1 \cdot z_e \cdot P_{\text{spec}}} \quad P [\text{kW}]$$

Drive load bearing characteristics

with given belt width [cm]
 $F_U = F_{U\text{spec}} \cdot z_e \cdot b \quad [\text{N}]$

$$M = \frac{M_{\text{spec}} \cdot z_1 \cdot z_e \cdot b}{100} \quad [\text{Nm}]$$

$$P = \frac{P_{\text{spec}} \cdot z_1 \cdot z_e \cdot b}{1000} \quad [\text{kW}]$$

intermeshing number of teeth

$$z_{\text{emax}} = 12$$

$$z_e = \frac{z_1}{180} \cdot \arccos \frac{t \cdot (z_2 - z_1)}{2\pi \cdot a}$$

1. Tooth shear strength (specific belt tooth load bearing)

R.p.m. n [rpm]	$F_{U\text{spec}}$ [N/cm]	M_{spec} [Ncm/cm]	P_{spec} [W/cm]	R.p.m. n [rpm]	$F_{U\text{spec}}$ [N/cm]	M_{spec} [Ncm/cm]	P_{spec} [W/cm]
0	50,5	8,04	0,000	2800	22,70	3,620	10,60
20	49,0	7,80	0,163	3000	22,20	3,530	11,08
40	47,7	7,60	0,318	3200	21,70	3,450	11,55
60	46,6	7,42	0,466	3400	21,20	3,360	11,99
80	45,7	7,27	0,609	3600	20,70	3,300	12,42
100	44,8	7,13	0,746	3800	20,30	3,230	12,84
200	41,4	6,60	1,381	4000	19,86	3,160	13,24
300	39,1	6,22	1,953	4500	18,91	3,010	14,18
400	37,2	5,92	2,480	5000	18,06	2,870	15,05
500	35,7	5,68	2,980	5500	17,28	2,750	15,84
600	34,4	5,48	3,440	6000	16,58	2,640	16,58
700	33,3	5,31	3,890	6500	15,93	2,540	17,26
800	32,4	5,15	4,320	7000	15,33	2,440	17,88
900	31,5	5,01	4,730	7500	14,76	2,350	18,46
1000	30,7	4,89	5,120	8000	14,24	2,270	18,99
1100	30,0	4,77	5,500	8500	13,74	2,180	19,47
1200	29,3	4,67	5,870	9000	13,28	2,110	19,92
1300	28,7	4,57	6,220	9500	12,84	2,040	20,30
1400	28,2	4,48	6,570	10000	12,42	1,976	20,70
1500	27,6	4,40	6,910				
1600	27,1	4,32	7,230				
1700	26,7	4,24	7,550				
1800	26,2	4,17	7,860				
1900	25,8	4,10	8,160				
2000	25,4	4,04	8,460				
2200	24,6	3,92	9,030				
2400	23,9	3,81	9,580				
2600	23,3	3,71	10,100				

Rotational speeds over 10000 rpm and/or belt speeds over 60 m/s are in need of a special drive design. Please request for our advice.

2. Tension cord strength (permitted tensile force of the belt F_{adm}), belt weight

Belt width	b	[mm]	16	25	32	50	75	100
BRECOFLEX®	F_{adm}	[N]	1000	1800	2300	3800	5800	7800
Belt weight	T10	[kg/m]	0,068	0,114	0,145	0,227	0,341	0,454
	T10-DL	[kg/m]	0,090	0,143	0,183	0,288	0,432	0,577
	T10-DR	[kg/m]	0,119	0,185	0,237	0,372	0,558	0,795
	T10-T	[kg/m]	0,107	0,170	0,217	0,342	0,513	0,685

3. Flexibility (Minimum numbers of teeth, minimum diameter)

Drive type	BFX T10					BFX T10-DR	
	BFX T10	BFX T10-E	BFX T10-DL-E	BFX T10-DL	BFX T10-T	BFX T10-DR	BFX T10-T
without contraflexure	Synchronising pulley Tension roller (smooth), running on teeth	z_{min}	12	10	15	20	20*
		d_{min} [mm]	60	50	50	60	60
with contraflexure	Synchronising pulley Tension roller (smooth), running on the back of the belt	z_{min}	20	15	15	20	20
		d_{min} [mm]	60	50	50	60	80

*Rotational speed limitation

T standard timing belts - endless

SYNCHROFLEX® TIMING BELT (SFX)

T 20

T 20-DL

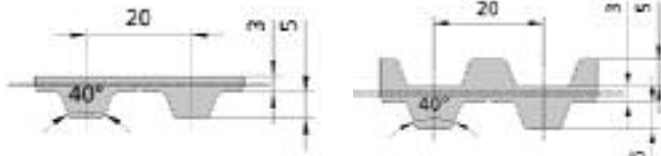

Type/ Length	Number of teeth	Type/ Length	Number of teeth
T 20 / 1260	63	T 20 / 2600	130
T 20 / 1460	73	T 20 / 2600 DL*	130
T 20 / 1780	89	T 20 / 3100	155
T 20 / 1880	94	T 20 / 3620	181
T 20 / 2360	118	T 20 / 3620 DL*	181

* Request application-dependent information

Standard T profile according to DIN 7721 with metric pitch and trapezoidal teeth.

Preferred belt length mm 32 50 75 100
In-between widths and larger widths are available

Other dimension upon request.

The technical data refer to polyurethane standard material and standard steel cord tension members.

Available versions:

- **T 20:** single-sided (as standard)
- with E tension member for a better flexibility
- with Aramid steel cord tension member (except DL)
- Polyurethane special materials upon request
- antistatic, coloured, mechanical reworked
- **DL:** double-sided

Order example:

SYNCHROFLEX®-TIMING BELT 50 T20 / 2600

Belt width in mm _____

Type / Pitch _____

Belt length in mm _____

Technical data of the SYNCHROFLEX® TIMING BELT

T 20, T 20-DL

Belt width b[cm]

$$b = \frac{F_U}{z_e \cdot F_{U\text{spec}}} \quad F_U [\text{N}]$$

$$b = \frac{100 \cdot M}{z_1 \cdot z_e \cdot M_{\text{spec}}} \quad M [\text{Nm}]$$

$$b = \frac{1000 \cdot P}{z_1 \cdot z_e \cdot P_{\text{spec}}} \quad P [\text{kW}]$$

Drive load bearing characteristics

with given belt width [cm]

$$F_U = F_{U\text{spec}} \cdot z_e \cdot b \quad [\text{N}]$$

$$M = \frac{M_{\text{spec}} \cdot z_1 \cdot z_e \cdot b}{100} \quad [\text{Nm}]$$

$$P = \frac{P_{\text{spec}} \cdot z_1 \cdot z_e \cdot b}{1000} \quad [\text{kW}]$$

intermeshing number of teeth

$$z_{\text{emax}} = 12$$

$$z_e = \frac{z_1}{180} \cdot \arccos \frac{t \cdot (z_2 - z_1)}{2\pi \cdot a}$$

1. Tooth shear strength (specific belt tooth load bearing)

R.p.m. n [rpm]	F _{Uspec} [N/cm]	M _{spec} [Ncm/cm]	P _{spec} [W/cm]	R.p.m. n [rpm]	F _{Uspec} [N/cm]	M _{spec} [Ncm/cm]	P _{spec} [W/cm]
0	101,5	32,30	0,000	2800	39,4	12,53	36,7
20	98,1	31,20	0,654	3000	38,1	12,13	38,1
40	95,3	30,30	1,271	3200	37,0	11,77	39,4
60	92,8	29,50	1,856	3400	35,9	11,42	40,7
80	90,7	28,90	2,420	3600	34,9	11,09	41,8
100	88,7	28,20	2,960	3800	33,9	10,78	42,9
200	81,2	25,90	5,420	4000	33,0	10,49	43,9
300	75,9	24,20	7,590	4500	30,8	9,81	46,2
400	71,8	22,90	9,570	5000	28,9	9,21	48,2
500	68,4	21,80	11,410	5500	27,2	8,66	49,9
600	65,6	20,90	13,110	6000	25,6	8,16	51,2
700	63,1	20,10	14,730	6500	24,2	7,69	52,4
800	60,9	19,40	16,250				
900	59,0	18,78	17,700				
1000	57,2	18,22	19,080				
1100	55,6	17,71	20,400				
1200	54,2	17,24	21,700				
1300	52,8	16,80	22,900				
1400	51,5	16,40	24,000				
1500	50,3	16,02	25,200				
1600	49,2	15,66	26,200				
1700	48,2	15,33	27,300				
1800	47,2	15,01	28,300				
1900	46,2	14,71	29,300				
2000	45,3	14,42	30,200				
2200	43,6	13,89	32,000				
2400	42,1	13,40	33,700				
2600	40,7	12,95	35,200				

Rotational speeds over 6500 rpm and/or belt speeds over 40 m/s are in need of a special drive design. Please request for our advice.

2. Tension cord strength (permitted tensile force of the belt F_{adm}), belt weight

Belt width	b	[mm]	32	50	75	100	150
SYNCHROFLEX®	F _{adm}	[N]	4750	7750	12000	16000	24500
Belt weight	T 20	[kg/m]	0,269	0,420	0,630	0,840	1,260
	T 20-DL	[kg/m]	0,355	0,555	0,833	1,110	1,665

3. Flexibility (Minimum numbers of teeth, minimum diameter)

Drive type	SFX T 20		
without contraflexure	Synchronising pulley	z _{min}	15
	Tension roller (smooth), running on teeth	d _{min} [mm]	120
with contraflexure	Synchronising pulley	z _{min}	25
	Tension roller (smooth), running on the back of the belt	d _{min} [mm]	120

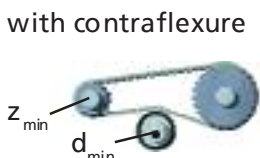
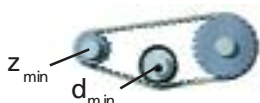

T standard timing belts - endless

BRECOFLEX® TIMING BELTS (BFX)

T 20

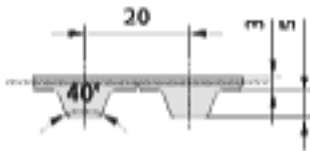

T 20-DL

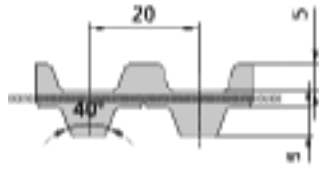

T 20-DR

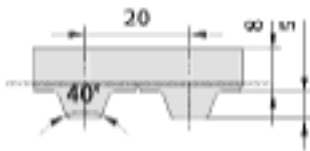

T 20-T

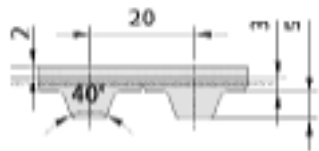

Endless lengths

Type / Length	Number of teeth	Type / Length	Number of teeth
T 20 / 1500	75	T 20 / 4760	238
T 20 / 1600	80	T 20 / 5000	250
T 20 / 1700	85	T 20 / 5300	265
T 20 / 1800	90	T 20 / 5600	280
T 20 / 1900	95	T 20 / 6000	300
T 20 / 2000	100	T 20 / 6300	315
T 20 / 2120	106	T 20 / 6700	335
T 20 / 2240	112	T 20 / 7100	355
T 20 / 2360	118	T 20 / 7500	375
T 20 / 2500	125	T 20 / 8000	400
T 20 / 2660	133	T 20 / 8500	425
T 20 / 2800	140	T 20 / 9000	450
T 20 / 3000	150		
T 20 / 3160	158		
T 20 / 3360	168		
T 20 / 3560	178		
T 20 / 3760	188		
T 20 / 4000	200		
T 20 / 4260	213		
T 20 / 4500	225		

Available endless lengths for T20

- Preferred lengths refer to table
- under 1500 mm: Further lengths on request
- over 1500 mm: Any number of teeth available, request minimum purchase amount for in-between lengths
- over 20000 mm: on request
- *) 150 mm belt width available from 1500 mm to 15000 mm

Available versions:

- **T 20:** Standard, single-sided
- **DL:** Standard, double-sided, available belt width up to $b_{max}=100$ mm, minimum purchase amount for length over 5300 mm on request
- **PAZ:** Nylon tooth facing
- **DL-PAZ:** Nylon on double-sided belts, only inner side can be coated available belt width up to $b_{max}=100$ mm, minimum purchase amount for length over 3760 mm on request
- **T, T-PAZ:** Transport support, available belt width up to $b_{max}=100$ mm, minimum purchase amount on request
- **DR, DR-PAZ:** Reinforced back of the belt, through 5 mm larger belt thickness, available belt width up to $b_{max}=100$ mm, minimum purchase amount on request

Preferred belt length mm 32 50 75 100 150*)

In-between belt widths are available

Order example:

BRECOFLEX®-TIMING BELT 100 T20 / 5300

Belt width in mm _____

Type / Pitch _____

Belt length in mm _____

Technical data of the BRECOFLEX® TIMING BELT

T 20, T 20-DL

Belt width b[cm]

$$b = \frac{F_U}{z_e \cdot F_{U\text{spec}}} \quad F_U [\text{N}]$$

$$b = \frac{100 \cdot M}{z_1 \cdot z_e \cdot M_{\text{spec}}} \quad M [\text{Nm}]$$

$$b = \frac{1000 \cdot P}{z_1 \cdot z_e \cdot P_{\text{spec}}} \quad P [\text{kW}]$$

Drive load bearing characteristics

with given belt width [cm]

$$F_U = F_{U\text{spec}} \cdot z_e \cdot b \quad [\text{N}]$$

$$M = \frac{M_{\text{spec}} \cdot z_1 \cdot z_e \cdot b}{100} \quad [\text{Nm}]$$

$$P = \frac{P_{\text{spec}} \cdot z_1 \cdot z_e \cdot b}{1000} \quad [\text{kW}]$$

intermeshing number of teeth

$$z_{\text{emax}} = 12$$

$$z_e = \frac{z_1 \cdot \arccos \frac{t \cdot (z_2 - z_1)}{2\pi \cdot a}}{180}$$

1. Tooth shear strength (specific belt tooth load bearing)



R.p.m. n [rpm]	$F_{U\text{spec}}$ [N/cm]	M_{spec} [Ncm/cm]	P_{spec} [W/cm]	R.p.m. n [rpm]	$F_{U\text{spec}}$ [N/cm]	M_{spec} [Ncm/cm]	P_{spec} [W/cm]
0	101,5	32,30	0,000	2800	39,4	12,53	36,7
20	98,1	31,20	0,654	3000	38,1	12,13	38,1
40	95,3	30,30	1,271	3200	37,0	11,77	39,4
60	92,8	29,50	1,856	3400	35,9	11,42	40,7
80	90,7	28,90	2,420	3600	34,9	11,09	41,8
100	88,7	28,20	2,960	3800	33,9	10,78	42,9
200	81,2	25,90	5,420	4000	33,0	10,49	43,9
300	75,9	24,20	7,590	4500	30,8	9,81	46,2
400	71,8	22,90	9,570	5000	28,9	9,21	48,2
500	68,4	21,80	11,410	5500	27,2	8,66	49,9
600	65,6	20,90	13,110	6000	25,6	8,16	51,2
700	63,1	20,10	14,730	6500	24,2	7,69	52,4
800	60,9	19,40	16,250				
900	59,0	18,78	17,700				
1000	57,2	18,22	19,080				
1100	55,6	17,71	20,400				
1200	54,2	17,24	21,700				
1300	52,8	16,80	22,900				
1400	51,5	16,40	24,000				
1500	50,3	16,02	25,200				
1600	49,2	15,66	26,200				
1700	48,2	15,33	27,300				
1800	47,2	15,01	28,300				
1900	46,2	14,71	29,300				
2000	45,3	14,42	30,200				
2200	43,6	13,89	32,000				
2400	42,1	13,40	33,700				
2600	40,7	12,95	35,200				

Rotational speeds over 6500 rpm and/or belt speeds over 40 m/s are in need of a special drive design. Please request for our advice.

2. Tension cord strength (permitted tensile force of the belt F_{adm}), belt weight

Belt width	b	[mm]	32	50	75	100	150
BRECOFLEX®	F_{adm}	[N]	4750	7750	12000	16000	24500
Belt weight	T 20	[kg/m]	0,236	0,368	0,552	0,736	1,095
	T 20-DL	[kg/m]	0,319	0,499	0,753	1,004	-
	T 20-DR	[kg/m]	0,430	0,675	1,016	1,354	-
	T 20-T	[kg/m]	0,315	0,495	0,746	0,994	-

3. Flexibility (Minimum numbers of teeth, minimum diameter)

Drive type		BFX T20	BFX T20-DL	BFX T20-DR	BFX T20-T	
without contraflexure 	Synchronising pulley	z_{min}	15	25	25	25
	Tension roller (smooth), running on teeth	d_{min} [mm]	120	120	150	120
with contraflexure 	Synchronising pulley	z_{min}	25	25	25	25
	Tension roller (smooth), running on the back of the belt	d_{min} [mm]	120	120	180	120

Imperial- timing belts - endless

SYNCHROFLEX® TIMING BELT (SFX)

M (MXL)

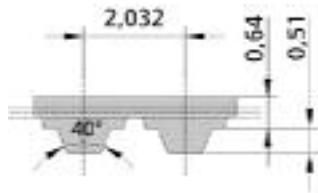

Standard trapezoidal teeth according to DIN/ISO 5296 with Minipitch (2.032mm=0.08 Inch).

The technical data refer to polyurethane standard material and standard steel cord tension members

Available versions:

- single-sided
- with Aramid tension member
- Polyurethane special materials upon request
- antistatic, coloured, mechanical reworked
- **FA:** with reinforced back of the belt
- **FN:** with profiles on the back of the belt

Type	Length	Number of teeth	Type	Length	Number of teeth
M 111	111,76	55	M 264	264,16	130
M 113	113,79	56	M 284	284,48	140
M 121	121,92	60	M 304	304,80	150
M 121 FA	121,92	60	M 355	355,60	175
M 132	132,08	65	M 373	373,89	184
M 142	142,24	70	M 449	449,07	221
M 144	144,27	71	M 503	503,94	248
M 162	162,56	80	M 508FN50	508,00	250
M 182	182,88	90	M 520	520,19	256
M 197	197,10	97	M 599	599,44	295
M 203	203,20	100	M 731	731,52	360
M 209	209,30	103	M1178	1178,56	580
M 213	213,36	105			
M 243	243,86	120			
M 256	256,03	126			

Preferred belt width b mm 4 6 10
In-between widths and larger widths are available.

Other dimension upon request.

Order example:

SYNCHROFLEX®-TIMING BELT 6 M / 182

Belt width in mm _____

Type / Pitch _____

Belt length in mm _____

Technical data of the SYNCHROFLEX® TIMING BELT
M (MXL)

Belt width b[cm]

$$b = \frac{F_U}{z_e \cdot F_{U\text{spec}}} \quad F_U [\text{N}]$$

$$b = \frac{100 \cdot M}{z_1 \cdot z_e \cdot M_{\text{spec}}} \quad M [\text{Nm}]$$

$$b = \frac{1000 \cdot P}{z_1 \cdot z_e \cdot P_{\text{spec}}} \quad P [\text{kW}]$$

Drive load bearing characteristics

with given belt width [cm]

$$F_U = F_{U\text{spec}} \cdot z_e \cdot b \quad [\text{N}]$$

$$M = \frac{M_{\text{spec}} \cdot z_1 \cdot z_e \cdot b}{100} \quad [\text{Nm}]$$

$$P = \frac{P_{\text{spec}} \cdot z_1 \cdot z_e \cdot b}{1000} \quad [\text{kW}]$$

intermeshing number of teeth

$$z_{\text{emax}} = 12$$

$$z_e = \frac{z_1}{180} \cdot \arccos \frac{t \cdot (z_2 - z_1)}{2\pi \cdot a}$$



1. Tooth shear strength (specific belt tooth load bearing)

R.p.m. n [rpm]	F _{U spec} [N/cm]	M _{spec} [Ncm/cm]	P _{spec} [W/cm]	R.p.m. n [rpm]	F _{U spec} [N/cm]	M _{spec} [Ncm/cm]	P _{spec} [W/cm]
0	6,58	0,209	0,000	2200	3,50	0,111	0,257
20	6,36	0,202	0,004	2400	3,42	0,109	0,274
40	6,18	0,197	0,008	2500	3,39	0,108	0,282
60	6,03	0,192	0,012	2600	3,35	0,107	0,290
80	5,90	0,188	0,016	2800	3,29	0,105	0,307
100	5,79	0,184	0,019	2880	3,26	0,104	0,313
150	5,56	0,177	0,028	3000	3,23	0,103	0,323
200	5,38	0,171	0,036	3200	3,17	0,101	0,338
300	5,10	0,162	0,051	3400	3,12	0,099	0,354
400	4,89	0,156	0,065	3600	3,07	0,098	0,368
500	4,72	0,150	0,079	3800	3,02	0,096	0,383
600	4,58	0,146	0,092	4000	2,98	0,095	0,397
700	4,45	0,142	0,104	4500	2,88	0,092	0,432
730	4,42	0,141	0,108	5000	2,78	0,088	0,463
800	4,35	0,138	0,116	5500	2,70	0,086	0,495
900	4,25	0,135	0,127	6000	2,63	0,084	0,526
1000	4,16	0,132	0,139	6500	2,56	0,081	0,555
1100	4,08	0,130	0,150	7000	2,49	0,079	0,581
1200	4,01	0,128	0,160	7500	2,43	0,077	0,607
1300	3,94	0,125	0,171	8000	2,37	0,075	0,632
1400	3,88	0,124	0,181	8500	2,32	0,074	0,657
1460	3,85	0,123	0,187	9000	2,27	0,072	0,681
1500	3,82	0,122	0,191	9500	2,22	0,071	0,703
1600	3,77	0,120	0,201	10000	2,18	0,069	0,727
1700	3,72	0,118	0,211	12000	2,02	0,064	0,808
1800	3,67	0,117	0,220	15000	1,82	0,058	0,910
1900	3,62	0,115	0,229	18000	1,66	0,053	0,996
2000	3,58	0,114	0,239	20000	1,57	0,050	1,047

2. Tension cord strength (permitted tensile force of the belt F_{adm}), belt weight

Belt width	b	[mm]	4	6	10	16	25	32
SYNCHROFLEX®	F _{adm}	[N]	39	65	117	195	312	403
Belt weight	M	[kg/m]	0,005	0,007	0,012	0,019	0,030	0,038

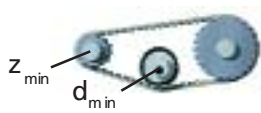
3. Flexibility (Minimum numbers of teeth, minimum diameter)

Drive type	SFX M		
without contraflexure	Synchronising pulley	z _{min}	10
	Tension roller (smooth), running on teeth	d _{min} [mm]	15
	with contraflexure	Synchronising pulley	z _{min}
	Tension roller (smooth), running on the back of the belt	d _{min} [mm]	15

Imperial- timing belts - endless

BRECOFLEX® TIMING BELTS (BFX)

XL mit Polyamidgewebe

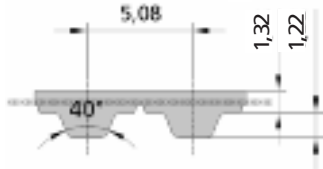

1/5" = 5,08 mm

Available endless lengths for XL

- Preferred lengths refer to table
- Further lengths on request.

Available versions:

- **XL:** Standard, single-sided, with Nylon tooth facing

Endless lengths

Length code / Pitch	Length mm	Number of teeth	Length code / Pitch	Length mm	Number of teeth
60 XL	152,40	30	210 XL	533,40	105
70 XL	177,80	35	220 XL	558,80	110
80 XL	203,20	40	230 XL	584,20	115
90 XL	228,60	45	240 XL	609,60	120
100 XL	254,00	50	250 XL	635,00	125
110 XL	279,40	55	260 XL	660,40	130
120 XL	304,80	60			
130 XL	330,20	65			
140 XL	355,60	70			
150 XL	381,00	75			
160 XL	406,40	80			
170 XL	431,80	85			
180 XL	457,20	90			
190 XL	482,60	95			
200 XL	508,00	100			

Preferred belt width b (in-between widths are available)

Imperial code: 025 031 037 050 075 100
 mm: 6,35 7,94 9,53 12,7 19,1 25,4

Order example:

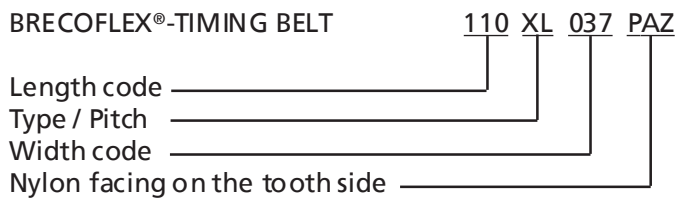

Technical data of the BRECOFLEX® TIMING BELT

XL

Belt width b[cm]

$$b = \frac{F_U}{z_e \cdot F_{U\text{spec}}} \quad F_U [\text{N}]$$

$$b = \frac{100 \cdot M}{z_1 \cdot z_e \cdot M_{\text{spec}}} \quad M [\text{Nm}]$$

$$b = \frac{1000 \cdot P}{z_1 \cdot z_e \cdot P_{\text{spec}}} \quad P [\text{kW}]$$

Drive load bearing characteristics

with given belt width [cm]

$$F_U = F_{U\text{spec}} \cdot z_e \cdot b \quad [\text{N}]$$

$$M = \frac{M_{\text{spec}} \cdot z_1 \cdot z_e \cdot b}{100} \quad [\text{Nm}]$$

$$P = \frac{P_{\text{spec}} \cdot z_1 \cdot z_e \cdot b}{1000} \quad [\text{kW}]$$

intermeshing number of teeth

$$z_{\text{emax}} = 12$$

$$z_e = \frac{z_1 \cdot \arccos \frac{t \cdot (z_2 - z_1)}{2\pi \cdot a}}{180}$$

1. Tooth shear strength (specific belt tooth load bearing)



R.p.m. n [rpm]	F _{Uspec} [N/cm]	M _{spec} [Ncm/cm]	P _{spec} [W/cm]	R.p.m. n [rpm]	F _{Uspec} [N/cm]	M _{spec} [Ncm/cm]	P _{spec} [W/cm]
0	24,40	1,973	0,000	2800	12,80	1,035	3,06
20	23,80	1,922	0,040	3000	12,57	1,017	3,19
40	23,20	1,879	0,079	3200	12,36	0,999	3,35
60	22,80	1,842	0,116	3400	12,16	0,983	3,50
80	22,40	1,809	0,152	3600	11,96	0,967	3,65
100	22,00	1,780	0,186	3800	11,78	0,953	3,79
200	20,60	1,667	0,349	4000	11,61	0,939	3,93
300	19,63	1,587	0,498	4500	11,21	0,907	4,27
400	18,86	1,525	0,639	5000	10,86	0,878	4,60
500	18,23	1,474	0,772	5500	10,54	0,852	4,91
600	17,70	1,431	0,899	6000	10,24	0,828	5,20
700	17,24	1,394	1,022	6500	9,97	0,806	5,49
800	16,83	1,361	1,140	7000	9,72	0,786	5,76
900	16,47	1,332	1,255	7500	9,49	0,767	6,02
1000	16,14	1,305	1,367	8000	9,27	0,749	6,28
1100	15,84	1,281	1,475	8500	9,06	0,732	6,52
1200	15,57	1,259	1,582	9000	8,86	0,717	6,76
1300	15,31	1,238	1,685	9500	8,68	0,702	6,98
1400	15,07	1,219	1,787	10000	8,51	0,688	7,20
1500	14,85	1,201	1,886				
1600	14,64	1,184	1,984				
1700	14,45	1,168	2,080				
1800	14,26	1,153	2,170				
1900	14,08	1,139	2,270				
2000	13,91	1,125	2,360				
2200	13,60	1,100	2,530				
2400	13,31	1,076	2,710				
2600	13,05	1,055	2,870				

Rotational speeds over 10000 rpm and/or belt speeds over 60 m/s are in need of a special drive design. Please request for our advice.

2. Tension cord strength (permitted tensile force of the belt F_{adm}), belt weight

Belt width	b	[mm]	6,35	7,94	9,53	12,7	19,1	25,4
BRECOFLEX®	F _{adm}	[N]	180	240	300	420	690	930
Belt weight	XL	[kg/m]	0,016	0,020	0,024	0,030	0,380	0,061

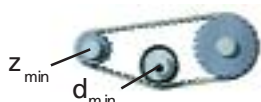
3. Flexibility (Minimum numbers of teeth, minimum diameter)

Drive type	BFX XL		
without contraflexure	Synchronising pulley	z _{min}	10
	Tension roller (smooth), running on teeth	d _{min} [mm]	30
with contraflexure	Synchronising pulley	z _{min}	15
	Tension roller (smooth), running on the back of the belt	d _{min} [mm]	30

Imperial- timing belts - endless

BRECOFLEX®-TIMING BELTS (BFX)

L

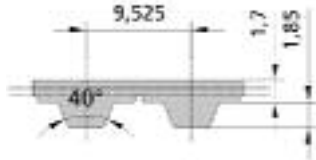

3/8" = 9,525 mm

Available endless lengths for L

- Preferred lengths refer to table
- under 1066,8 mm: further lengths upon request.
- over 1066,8 mm: Any number of teeth available, request minimum purchase amount for in-between lengths
- over 14992,35 mm on request

Available versions:

- L: Standard, single-sided
- PAZ: Nylon tooth facing

Endless lengths

Length code / Pitch	Length mm	Number of teeth	Length code / Pitch	Length mm	Number of teeth
124 L	314,33	33	420 L	1066,80	112
150 L	381,00	40	450 L	1143,00	120
187 L	476,25	50	480 L	1219,20	128
202 L	514,35	54	540 L	1371,60	144
210 L	533,40	56	570 L	1447,80	152
225 L	571,50	60	600 L	1524,00	160
240 L	609,60	64	630 L	1600,20	168
255 L	647,70	68	660 L	1676,40	176
270 L	685,80	72	705 L	1790,70	188
285 L	723,90	76	750 L	1905,00	200
300 L	762,00	80	current maximum manufacturing length:		
322 L	819,15	86	5902 L	14992,35	1574
345 L	876,30	92			
367 L	933,45	98			
390 L	990,60	104			

Preferred belt width b (in-between widths are available)

Imperial code:	037	050	075	100	200	400
mm:	9,53	12,7	19,1	25,4	50,8	101,6

Order example:

BRECOFLEX®-TIMING BELT	210	L	075
Length code	_____		
Type / Pitch	_____		
Width code	_____		

Technical data of the BRECOFLEX® TIMING BELT

L

Belt width b[cm]

$$b = \frac{F_U}{z_e \cdot F_{U\text{spec}}} \quad F_U [\text{N}]$$

$$b = \frac{100 \cdot M}{z_1 \cdot z_e \cdot M_{\text{spec}}} \quad M [\text{Nm}]$$

$$b = \frac{1000 \cdot P}{z_1 \cdot z_e \cdot P_{\text{spec}}} \quad P [\text{kW}]$$

Drive load bearing characteristics

with given belt width [cm]

$$F_U = F_{U\text{spec}} \cdot z_e \cdot b \quad [\text{N}]$$

$$M = \frac{M_{\text{spec}} \cdot z_1 \cdot z_e \cdot b}{100} \quad [\text{Nm}]$$

$$P = \frac{P_{\text{spec}} \cdot z_1 \cdot z_e \cdot b}{1000} \quad [\text{kW}]$$

intermeshing number of teeth

$$z_{\text{emax}} = 12$$

$$z_e = \frac{z_1}{180} \cdot \arccos \frac{t \cdot (z_2 - z_1)}{2\pi \cdot a}$$

1. Tooth shear strength (specific belt tooth load bearing)

R.p.m. n [rpm]	$F_{U\text{spec}}$ [N/cm]	M_{spec} [Ncm/cm]	P_{spec} [W/cm]	R.p.m. n [rpm]	$F_{U\text{spec}}$ [N/cm]	M_{spec} [Ncm/cm]	P_{spec} [W/cm]
0	37,40	5,67	0,000	2800	16,81	2,550	7,47
20	36,30	5,50	0,115	3000	16,40	2,490	7,81
40	35,30	5,35	0,224	3200	16,02	2,430	8,14
60	34,50	5,23	0,329	3400	15,66	2,370	8,45
80	33,80	5,12	0,429	3600	15,32	2,320	8,76
100	33,10	5,02	0,526	3800	15,00	2,270	9,05
200	30,70	4,65	0,974	4000	14,69	2,230	9,33
300	28,90	4,38	1,377	4500	13,99	2,120	9,99
400	27,50	4,18	1,749	5000	13,36	2,030	10,61
500	26,40	4,01	2,100	5500	12,79	1,939	11,17
600	25,50	3,86	2,430	6000	12,27	1,860	11,69
700	24,70	3,74	2,740	6500	11,79	1,787	12,16
800	24,00	3,63	3,040	7000	11,34	1,719	12,60
900	23,30	3,53	3,330	7500	10,93	1,656	13,01
1000	22,70	3,45	3,610	8000	10,54	1,597	13,38
1100	22,20	3,37	3,880	8500	10,17	1,542	13,72
1200	21,70	3,29	4,140	9000	9,83	1,490	14,04
1300	21,30	3,22	4,390	9500	9,50	1,440	14,33
1400	20,80	3,16	4,630	10000	9,19	1,393	14,59
1500	20,40	3,10	4,870				
1600	20,10	3,04	5,100				
1700	19,72	2,99	5,320				
1800	19,39	2,94	5,540				
1900	19,08	2,89	5,750				
2000	18,78	2,85	5,960				
2200	18,22	2,76	6,370				
2400	17,71	2,69	6,750				
2600	17,25	2,61	7,120				

Rotational speeds over 10000 rpm and/or belt speeds over 60 m/s are in need of a special drive design. Please request for our advice.

2. Tension cord strength (permitted tensile force of the belt F_{adm}), belt weight

Belt width	b	[mm]	9,53	12,7	19,1	25,4	38,1	50,8	76,2	101,6
BRECOFLEX®	F_{adm}	[N]	630	910	1470	2030	3150	4270	6510	8750
Belt weight	L	[kg/m]	0,038	0,044	0,066	0,088	0,133	0,178	0,266	0,356

3. Flexibility (Minimum numbers of teeth, minimum diameter)

Drive type

without contraflexure



with contraflexure



			BFX L
Synchronising pulley	z_{min}		15
Tension roller (smooth), running on teeth	d_{min} [mm]		60
Synchronising pulley	z_{min}		20
Tension roller (smooth), running on the back of the belt	d_{min} [mm]		60

Imperial- timing belts - endless

BRECOFLEX®-ZAHNRIEMEN (BFX)

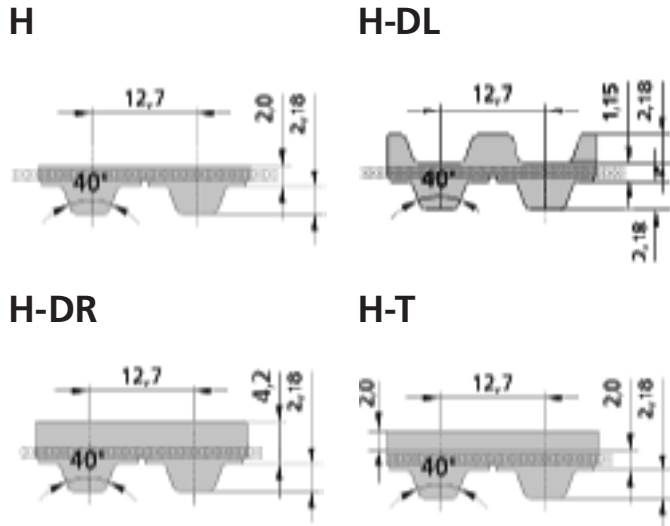

1/2" = 12,7 mm

Available endless lengths for H

- Preferred lengths refer to table
- under 1066,8 mm: Further lengths on request
- over 1066,8 mm: Any number of teeth available, request minimum purchase amount for in-between lengths
- over 16002.0 mm: On request

Available versions:

- **H:** Standard, single-sided
- **DL:** Standard, double-sided, available over 1066.8 mm, for length over 1250 H request for minimum purchase amount
- **PAZ:** Nylon tooth facing
- **DL-PAZ:** Nylon facing on double-sided belts, only inner side can be coated, for length over 1250 H request for minimum purchase amount
- **T, T-PAZ:** Transport support, minimum purchase amount on request
- **DR, DR-PAZ:** Reinforced back of the belt, through 2.18 mm larger belt thickness, available in lengths over 1066.8 mm, minimum purchase amount on request

Endless lengths

Length code / Pitch	Length mm	Number of teeth	Length code / Pitch	Length mm	Number of teeth
420 H	1066,80	84	1100 H	2794,00	220
450 H	1143,00	90	1250 H	3175,00	250
480 H	1219,20	96	1400 H	3556,00	280
510 H	1295,40	102	1700 H	4318,00	340
540 H	1371,60	108	2000 H	5080,00	400
570 H	1447,80	114	2300 H	5842,00	460
600 H	1524,00	120	2600 H	6604,00	520
630 H	1600,20	126	3000 H	7620,00	600
660 H	1676,40	132	current maximum manufacturing length:		
700 H	1778,00	140	6300 H	16002,00	1260
750 H	1905,00	150			
800 H	2032,00	160			
850 H	2159,00	170			
900 H	2286,00	180			
1000 H	2540,00	200			

Preferred belt width b (in-between widths are available)
 Imperial code: 050 075 100 150 200 300 400
 mm: 12,7 19,1 25,4 38,1 50,8 76,2 101,6

Order example:

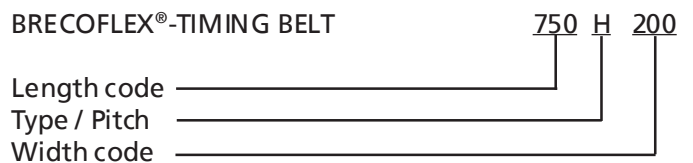

Technical data of the BRECOFLEX® TIMING BELT

H, H-DL

Belt width b[cm]

$$b = \frac{F_U}{z_e \cdot F_{U\text{spec}}} \quad F_U [\text{N}]$$

$$b = \frac{100 \cdot M}{z_1 \cdot z_e \cdot M_{\text{spec}}} \quad M [\text{Nm}]$$

$$b = \frac{1000 \cdot P}{z_1 \cdot z_e \cdot P_{\text{spec}}} \quad P [\text{kW}]$$

Drive load bearing characteristics

with given belt width [cm]

$$F_U = F_{U\text{spec}} \cdot z_e \cdot b \quad [\text{N}]$$

$$M = \frac{M_{\text{spec}} \cdot z_1 \cdot z_e \cdot b}{100} \quad [\text{Nm}]$$

$$P = \frac{P_{\text{spec}} \cdot z_1 \cdot z_e \cdot b}{1000} \quad [\text{kW}]$$

intermeshing number of teeth

$$z_{\text{emax}} = 12$$

$$z_e = \frac{z_1}{180} \cdot \arccos \frac{t \cdot (z_2 - z_1)}{2\pi \cdot a}$$

1. Tooth shear strength (specific belt tooth load bearing)

R.p.m. n [rpm]	F _{U spec} [N/cm]	M _{spec} [Ncm/cm]	P _{spec} [W/cm]	R.p.m. n [rpm]	F _{U spec} [N/cm]	M _{spec} [Ncm/cm]	P _{spec} [W/cm]
0	44,0	8,90	0,000	2800	19,81	4,00	11,74
20	42,7	8,64	0,181	3000	19,33	3,91	12,27
40	41,6	8,41	0,352	3200	18,88	3,82	12,79
60	40,7	8,22	0,516	3400	18,45	3,73	13,28
80	39,8	8,05	0,674	3600	18,05	3,65	13,76
100	39,1	7,89	0,827	3800	17,68	3,57	14,22
200	36,1	7,30	1,530	4000	17,32	3,50	14,66
300	34,1	6,89	2,160	4500	16,49	3,33	15,70
400	32,5	6,56	2,750	5000	15,74	3,18	16,66
500	31,1	6,30	3,300	5500	15,07	3,05	17,55
600	30,0	6,07	3,810	6000	14,46	2,92	18,36
700	29,1	5,88	4,310	6500	13,89	2,81	19,11
800	28,2	5,71	4,780	7000	13,36	2,70	19,80
900	27,5	5,55	5,230	7500	12,87	2,60	20,40
1000	26,8	5,41	5,670	8000	12,42	2,51	21,00
1100	26,2	5,29	6,090	8500	11,99	2,42	21,60
1200	25,6	5,17	6,500	9000	11,58	2,34	22,10
1300	25,1	5,06	6,890	9500	11,19	2,26	22,50
1400	24,6	4,96	7,280	10000	10,83	2,19	22,90
1500	24,1	4,87	7,650				
1600	23,7	4,78	8,010				
1700	23,2	4,70	8,360				
1800	22,9	4,62	8,710				
1900	22,5	4,54	9,040				
2000	22,1	4,47	9,370				
2200	21,5	4,34	10,000				
2400	20,9	4,22	10,600				
2600	20,3	4,11	11,180				

Rotational speeds over 10000 rpm and/ or belt speeds over 60 m/s are in need of a special drive design. Please request for our advice.

2. Tension cord strength (permitted tensile force of the belt F_{adm}), belt weight

Belt width	b	[mm]	12,7	19,1	25,4	38,1	50,8	76,2	101,6
BRECOFLEX®	F _{adm}	[N]	800	1300	1800	2800	3800	5800	7900
Belt weight	H	[kg/m]	0,053	0,079	0,108	0,161	0,216	0,324	0,432
	H-DL	[kg/m]	0,064	0,097	0,130	0,196	0,262	0,394	0,527
	H-DR	[kg/m]	0,085	0,128	0,171	0,258	0,345	0,518	0,692
	H-T	[kg/m]	0,082	0,124	0,165	0,249	0,333	0,499	0,668

3. Flexibility (Minimum numbers of teeth, minimum diameter)

Drive type		BFX H	BFX H-DL	BFX H-DR	BFX H-T	
without contraflexure	Synchronising pulley	z _{min}	14	20	20	20
	Tension roller (smooth), running on teeth	d _{min} [mm]	60	60	80	80
with contraflexure	Synchronising pulley	z _{min}	20	20	20	20
	Tension roller (smooth), running on the back of the belt	d _{min} [mm]	80	80	80	80

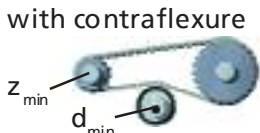
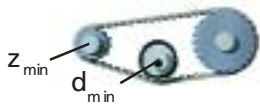

Imperial- timing belts - endless

BRECOFLEX®-ZAHNRIEMEN (BFX)

XH

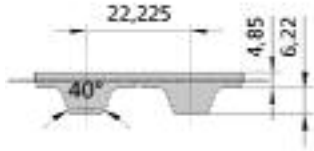

7/8" = 22,225 mm

Endless lengths

Length code / Pitch	Length mm	Number of teeth	Length code / Pitch	Length mm	Number of teeth
560 XH	1422,40	64	1750 XH	4445,00	200
630 XH	1600,20	72	1960 XH	4978,40	224
700 XH	1778,00	80	2275 XH	5778,50	260
770 XH	1955,80	88	2450 XH	6223,00	280
840 XH	2133,60	96	3500 XH	8890,00	400
980 XH	2489,20	112	current maximum manufacturing length:		
1120 XH	2844,80	128			
1260 XH	3200,40	144			
1400 XH	3556,00	160			
1540 XH	3911,60	176			
			6300 XH	16002,00	720

Preferred belt width b (in-between widths are available)

Imperial code:	200	300	400
mm:	50,8	76,2	101,6

Available endless lengths for XH

- Preferred lengths refer to table
- under 1422.4 mm: Further lengths on request
- over 1422,4 mm: Any number of teeth available, request minimum purchase amount for in-between lengths
- over 16002,00 mm On request

Available versions:

- **XH:** Standard, single-sided
- **PAZ:** Nylon tooth facing

Order example:

BRECOFLEX®-TIMING BELT	700	XH	200
Length code	_____		
Type / Pitch	_____		
Width code	_____		

Technical data of the BRECOFLEX® TIMING BELT

XH

Belt width b[cm]

$$b = \frac{F_U}{z_e \cdot F_{U\text{spec}}} \quad F_U [\text{N}]$$

$$b = \frac{100 \cdot M}{z_1 \cdot z_e \cdot M_{\text{spec}}} \quad M [\text{Nm}]$$

$$b = \frac{1000 \cdot P}{z_1 \cdot z_e \cdot P_{\text{spec}}} \quad P [\text{kW}]$$

Drive load bearing characteristics

with given belt width [cm]

$$F_U = F_{U\text{spec}} \cdot z_e \cdot b \quad [\text{N}]$$

$$M = \frac{M_{\text{spec}} \cdot z_1 \cdot z_e \cdot b}{100} \quad [\text{Nm}]$$

$$P = \frac{P_{\text{spec}} \cdot z_1 \cdot z_e \cdot b}{1000} \quad [\text{kW}]$$

intermeshing number of teeth

$$z_{e\text{max}} = 12$$

$$z_e = \frac{z_1}{180} \cdot \arccos \frac{t \cdot (z_2 - z_1)}{2\pi \cdot a}$$

1. Tooth shear strength (specific belt tooth load bearing)

R.p.m. n [rpm]	$F_{U\text{spec}}$ [N/cm]	M_{spec} [Ncm/cm]	P_{spec} [W/cm]	R.p.m. n [rpm]	$F_{U\text{spec}}$ [N/cm]	M_{spec} [Ncm/cm]	P_{spec} [W/cm]
0	91,35	29,070	0,000	2800	35,46	11,277	33,030
20	88,29	28,080	0,589	3000	34,29	10,917	34,290
40	85,77	27,270	1,144	3200	33,30	10,593	35,460
60	83,52	26,550	1,670	3400	32,31	10,278	36,630
80	81,63	26,010	2,178	3600	31,41	9,981	37,620
100	79,83	25,380	2,664	3800	30,51	9,702	38,610
200	73,08	23,310	4,878	4000	29,70	9,441	39,510
300	68,31	21,780	6,831	4500	27,72	8,829	41,580
400	64,62	20,610	8,613				
500	61,56	19,620	10,269				
600	59,04	18,810	11,799				
700	56,79	18,090	13,257				
800	54,81	17,460	14,625				
900	53,10	16,902	15,930				
1000	51,48	16,398	17,172				
1100	50,04	15,939	18,360				
1200	48,78	15,516	19,530				
1300	47,52	15,120	20,610				
1400	46,35	14,760	21,600				
1500	45,27	14,418	22,680				
1600	44,28	14,094	23,580				
1700	43,38	13,797	24,570				
1800	42,48	13,509	25,470				
1900	41,58	13,239	26,370				
2000	40,77	12,978	27,180				
2200	39,24	12,501	28,800				
2400	37,89	12,060	30,330				
2600	36,63	11,665	31,680				

Rotational speeds over 4500 rpm and/or belt speeds over 40 m/s are in need of a special drive design. Please request for our advice.

2. Tension cord strength (permitted tensile force of the belt F_{adm}), belt weight

Belt width	b	[mm]	50,8	76,2	101,6
BRECOFLEX®	F_{adm}	[N]	7750	12000	16250
Belt weight	XH	[kg/m]	0,530	0,795	1,059

3. Flexibility (Minimum numbers of teeth, minimum diameter)

Drive type

without contraflexure

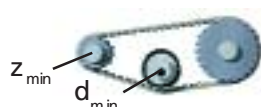

with contraflexure



		BFX XH	
without contraflexure	Synchronising pulley	z_{min}	18
	Tension roller (smooth), running on teeth	d_{min} [mm]	150
with contraflexure	Synchronising pulley	z_{min}	25
	Tension roller (smooth), running on the back of the belt	d_{min} [mm]	180

F- flat belts - endless

BRECOFLEX® FLAT BELTS (BFX)

F 2.0



Endless lengths

Type	Length	Type	Length
F 2.0	1500	F 2.0	2000
F 2.0	1550	F 2.0	2100
F 2.0	1600	F 2.0	2500
F 2.0	1650	F 2.0	3000
F 2.0	1700	F 2.0	4000
F 2.0	1750	F 2.0	5000
F 2.0	1800	current maximum manufacturing length: F 2.0 20000	
F 2.0	1850		
F 2.0	1900		
F 2.0	1950		
F 2.0	1950		

Preferred belt width

b [mm]: 25 32 50 75 100

In-between belt widths are available

Available endless lengths for F 2.0

- Preferred lengths refer to table
- under 1,500 mm: on request
- request for in-between lengths for the minimum purchase
- over 20,000 mm on request

Available versions for F 2.0

- **F 2.0:Standard**
- **PAZ:** Nylon tooth facing on the groove side

Order example:

BRECOFLEX®-FLATBELT 50 F2.0 / 2500 -PAZ

Belt width in mm _____

Type _____

Belt length in mm _____

Nylon facing on the groove side _____

Tension cord strength (permitted tensile force of the belt F_{adm}), belt weight

Belt width	b	[mm]	25	32	50	75	100
BRECOFLEX®	F_{adm}	[N]	1800	2300	3800	5800	7800
Belt weight	F 2.0	[kg/m]	0,067	0,098	0,155	0,234	0,313

Flexibility (minimum diameter)

Drive type

without contraflexure



with contraflexure

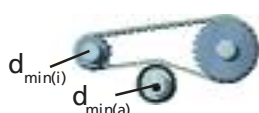

120

		F2.0
without contraflexure	Minimum diameter d_{min} [mm]	30
with contraflexure	internal minimum diameter $d_{min(i)}$ [mm]	40
	Tension roller (smooth), running on the back of the belt $d_{min(a)}$ [mm]	60

SYNCHROFLEX[®] FLAT BELT (SFX)

F, AF, BF, CF, DF

Type	Shape No.	Length l [mm]	e [mm]	u [mm]	d _e [mm]
F 213/7	K3969-Z	212,95	1,60	0,800	0,15
F 254/4	K5111-Z	253,74	0,80	0,400	0,15
F 314/5	K5558-Z	314,16	5,50	2,000	0,60
F 315/4	K5428-Z	315,73	1,20	0,600	0,15
F 330/2	K5651-Z	330,00	1,00	0,400	0,15
F 435/2	K5691-Z	435,00	0,80	0,400	0,15
F 502/7	K5430-Z	501,84	1,00	0,500	0,30
F 697/4	52648-Z	695,57	0,55	0,275	0,15
F 738/4	K5112-Z	738,64	0,80	0,400	0,15
F 762/7	K3708-Z	762,00	2,60	1,300	0,30
F 959/2	K5578-Z	959,40	1,00	0,500	0,30
F 1240/10	K5178-Z	1240,00	1,20	0,800	0,60
F 1458/9	K4377-Z	1458,50	2,60	0,450	0,30
F 1780/10	K4667-Z	1780,00	1,40	0,600	0,60
AF 24	51669-Z	113,08	0,80	0,275	0,15
AF 56	51772-Z	263,16	0,80	0,400	0,15
AF 67	51601-Z	315,70	0,70	0,275	0,15
AF 76	39669-Z	357,30	0,80	0,400	0,15
AF 87	38919-Z	409,57	0,85	0,575	0,15
AF 108	39796-Z	508,39	0,70	0,275	0,15
AF 138	39847-Z	649,60	0,80	0,275	0,15
AF 140	40121-Z	659,03	0,60	0,275	0,15
AF 148	39631-Z	695,57	0,80	0,275	0,15
BF 44	38852-Z	345,57	0,90	0,450	0,30
BF 64	38805-Z	501,85	0,90	0,450	0,30
BF 67	38902-Z	525,70	0,90	0,450	0,30
BF 70	39980-Z	548,90	0,90	0,450	0,30
CF 66	38917-Z	828,55	1,40	0,700	0,60
DF 45	39839-Z	282,74	0,90	0,450	0,30
DF 130	51636-Z	815,34	0,90	0,450	0,30
DF 153	39979-Z	959,40	0,90	0,450	0,30



Power transmission technology

Order example:

SYNCHROFLEX[®]-FLATBELT 10 AF 108

Belt width in mm _____
Type / No. of grooves _____

Timing belts with special profiles - endless

SYNCHROFLEX® TIMING BELT (SFX)

K 1

K 1,5

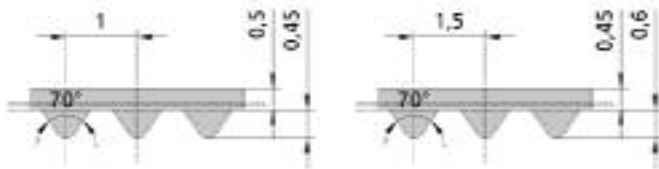

Notched profile with a metric pitch.

The technical data refer to standard casting polyurethane and standard steel cord tension members

Available versions:

- single-sided
- with Aramid tension member
- Polyurethane special materials upon request
- antistatic, coloured, mechanical reworked

Type/ Length	Number of teeth	Type/ Length	Number of teeth
K 1 / 279,0	279	K 1,5 / 600,0	400
K 1 / 348,0	348	K 1,5 / 1242,0	828
K 1,5 / 57,0*	38	K 1,5 / 1671,0	1114
K 1,5 / 64,5*	43		
K 1,5 / 100,5	67		
K 1,5 / 165,0	110		
K 1,5 / 201,0	134		
K 1,5 / 228,0	152		
K 1,5 / 286,0	191		
K 1,5 / 300,0	200		
K 1,5 / 400,5	267		
K 1,5 / 501,0	334		

*) in casting polyurethane DADU 9311, yellow colour

Preferred belt length mm 4 6 10
In-between widths and larger widths are available.

Other dimension upon request.

Order Example:

SYNCHROFLEX®-TIMING BELT 6 K 1,5 / 100,5

Belt width in mm _____

Type / Pitch _____

Belt length in mm _____

Technical data of the SYNCHROFLEX® TIMING BELT

K 1, K 1,5

Belt width b[cm]

$$b = \frac{F_U}{z_e \cdot F_{U\text{spec}}} \quad F_U [\text{N}]$$

$$b = \frac{100 \cdot M}{z_1 \cdot z_e \cdot M_{\text{spec}}} \quad M [\text{Nm}]$$

$$b = \frac{1000 \cdot P}{z_1 \cdot z_e \cdot P_{\text{spec}}} \quad P [\text{kW}]$$

Drive load bearing characteristics with given belt width [cm]

$$F_U = F_{U\text{spec}} \cdot z_e \cdot b \quad [\text{N}]$$

$$M = \frac{M_{\text{spec}} \cdot z_1 \cdot z_e \cdot b}{100} \quad [\text{Nm}]$$

$$P = \frac{P_{\text{spec}} \cdot z_1 \cdot z_e \cdot b}{1000} \quad [\text{kW}]$$

intermeshing number of teeth

$$z_{\text{emax}} = 12$$

$$z_e = \frac{z_1}{180} \cdot \arccos \frac{t \cdot (z_2 - z_1)}{2\pi \cdot a}$$



1. Tooth shear strength (specific belt tooth load bearing)

R.p.m. n [rpm]	F _{U spec} [N/cm]	M _{spec} [Ncm/cm]	P _{spec} [W/cm]	R.p.m. n [rpm]	F _{U spec} [N/cm]	M _{spec} [Ncm/cm]	P _{spec} [W/cm]
0	6,45	0,154	0,000	2200	3,43	0,082	0,189
20	6,23	0,149	0,003	2400	3,35	0,080	0,201
40	6,06	0,145	0,006	2500	3,32	0,079	0,207
60	5,91	0,141	0,009	2600	3,29	0,079	0,214
80	5,79	0,138	0,012	2800	3,22	0,077	0,225
100	5,68	0,136	0,014	2880	3,20	0,076	0,230
150	5,46	0,130	0,020	3000	3,17	0,076	0,238
200	5,28	0,126	0,026	3200	3,11	0,074	0,249
300	5,00	0,119	0,037	3400	3,06	0,073	0,260
400	4,80	0,115	0,048	3600	3,01	0,072	0,271
500	4,63	0,111	0,058	3800	2,96	0,071	0,281
600	4,49	0,107	0,067	4000	2,92	0,070	0,292
700	4,37	0,104	0,076	4500	2,82	0,067	0,317
730	4,33	0,103	0,079	5000	2,73	0,065	0,341
800	4,26	0,102	0,085	5500	2,65	0,063	0,364
900	4,17	0,100	0,094	6000	2,57	0,061	0,385
1000	4,08	0,097	0,102	6500	2,51	0,060	0,408
1100	4,00	0,095	0,110	7000	2,44	0,058	0,427
1200	3,93	0,094	0,118	7500	2,38	0,057	0,446
1300	3,87	0,092	0,126	8000	2,33	0,056	0,466
1400	3,81	0,091	0,133	8500	2,27	0,054	0,482
1460	3,77	0,090	0,138	9000	2,22	0,053	0,499
1500	3,75	0,090	0,141	9500	2,18	0,052	0,518
1600	3,69	0,088	0,148	10000	2,13	0,051	0,532
1700	3,64	0,087	0,155	12000	1,98	0,047	0,594
1800	3,60	0,086	0,162	15000	1,78	0,042	0,667
1900	3,55	0,085	0,169	18000	1,63	0,039	0,733
2000	3,51	0,084	0,175	20000	1,54	0,037	0,770

2. Tension cord strength (permitted tensile force of the belt F_{adm}), belt weight

Belt width	b	[mm]	4	6	10	16	25	32
SYNCHROFLEX® F _{adm}	[N]		39	65	117	195	312	403
Belt weight	K1.5	[kg/m]	0,0044	0,007	0,011	0,018	0,028	0,035
	K1	[kg/m]	0,004	0,006	0,010	0,016	0,025	0,032

3. Flexibility (Minimum numbers of teeth, minimum diameter)

Drive type		SFX K1	SFX K1,5
without contraflexure 	Synchronising pulley	z _{min}	14
	Tension roller (smooth), running on teeth	d _{min} [mm]	15
with contraflexure 	Synchronising pulley	z _{min}	20
	Tension roller (smooth), running on the back of the belt	d _{min} [mm]	15

Timing belts with special profiles - endless

SYNCHROFLEX® TIMING BELT (SFX)

V

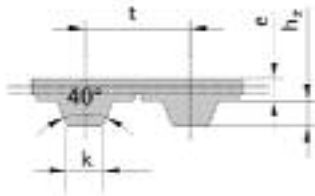

Order Example:

SYNCHROFLEX®-ZAHNRIEMEN 10 V 100 / 3 F
 Belt width in mm _____
 Type / Length code _____

Type	Imperial pitch	Shape No.	Length l [mm]	Pitch t [mm]	Module m	Number of teeth z	k [mm]	h _z [mm]	e [mm]
V 100/3 F		K4730-F	100,98	3,060	0,974	33	1,20	0,80	0,70
V 149/4 F		K5870-F	149,49	4,983	1,586	30	1,80	1,20	1,00
V 150/5 F		K3950-F	150,10	5,176	1,648	29	1,60	1,50	1,30
V 158/4 F		K4186-F	158,27	4,522	1,439	35	1,50	1,00	1,20
V 161/5 F		K3961-F	160,68	5,951	1,894	27	2,00	1,50	1,50
V 165/3 F		K3978-F	164,73	3,581	1,140	46	1,00	1,00	1,30
V 167/4 F		K3628-F	167,31	4,522	1,439	37	1,50	1,00	1,20
V 170/4 FA		K4503-FA	169,44	4,459	1,419	38	1,50	1,00	1,00
V 172/4 F		K3880-F	172,24	4,921	1,566	35	1,60	1,50	1,20
V 174/3 F		K5385-F	174,90	3,300	1,050	53	1,00	1,00	1,20
V 177/5 F	XL	K5841-F	177,80	5,080	1,617	35	1,20	1,20	0,85
V 190/4 F		K6238-F	192,02	4,572	1,455	42	1,30	1,20	1,40
V 203/5 F	XL	K5369-F	203,20	5,080	1,617	40	1,37	1,27	0,80
V 206/6 FK		K4662-FK	206,14	6,063	1,930	34	1,80	1,20	1,00
V 213/7 F		K3969-F	212,46	7,869	2,505	27	2,50	1,40	1,40
V 225/3 F		K6175-F	225,00	3,000	0,955	75	1,20	0,80	0,70
V 226/5 F		K4187-F	226,10	5,950	1,894	38	2,00	1,50	1,50
V 228/6 F		K5290-F	228,60	6,350	2,021	36	2,00	1,50	0,80
V 228/6 FA		K6222-FA	228,60	6,350	2,021	36	2,00	1,50	1,05
V 229/6 F		K3595-F	229,02	6,736	2,144	34	2,00	1,20	1,20
V 233/5 F	XL	K5674-F	233,68	5,080	1,617	46	1,37	1,22	1,28
V 238/5 F		K3964-F	238,04	5,951	1,894	40	2,00	1,50	1,10
V 242/5 F		K4088-F	242,40	5,050	1,607	48	1,60	1,50	1,20
V 248/7 F		K3319-F	247,69	7,285	2,319	34	2,50	1,40	1,50
V 252/6 K		K3264-K	252,53	6,475	2,061	39	2,20	1,20	1,80
V 255/6 FK		K4891-FK	255,25	6,717	2,138	38	2,50	1,80	1,00
V 261/7 K		K3251-K	261,59	7,927	2,523	33	2,50	1,40	1,00
V 265/8 F		K3436-F	264,63	8,019	2,553	33	2,50	1,40	1,50
V 268/7 F		K3944-F	268,55	7,258	2,310	37	2,50	1,80	1,50
V 277/3 F		K5386-F	277,20	3,300	1,050	84	1,00	1,00	1,20
V 279/6 F		K6250-F	279,40	6,350	2,021	44	2,00	1,50	1,05
V 284/5 F	XL	K5545-F	284,48	5,080	1,617	56	1,80	1,20	0,70
V 285/6 F		K5401-F	285,75	6,350	2,021	45	1,80	1,20	1,00
V 290/3 F		K5388-F	290,40	3,300	1,050	88	1,00	1,00	1,20
V 291/7 F		K3584-F	290,24	7,256	2,310	40	2,50	1,40	1,60
V 295/6 F		K3804-F	294,50	6,266	1,995	47	1,60	1,50	1,50
V 295/6 FA		K4469-FA	294,83	6,273	1,997	47	1,60	1,50	1,50
V 304/5 F	XL	K5368-F	304,80	5,080	1,617	60	1,37	1,27	0,60
V 307/5 F		K4031-F	306,92	5,202	1,656	59	1,60	1,50	1,30
V 309/7 FK		K4610-FK	310,72	7,226	2,300	43	2,20	1,60	1,30

Power transmission technology

SYNCHROFLEX® TIMING BELT (SFX)

V

Order Example:

SYNCHROFLEX®-ZAHNRIEMEN 10 V 100 / 3 F

Belt width in mm └───┬───┘

Type / Length code └───┬───┘

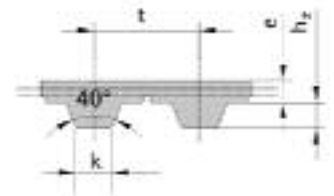

Type	Imperial pitch	Shape No.	Length l [mm]	Pitch t [mm]	Module m	Number of teeth z	k [mm]	h ₂ [mm]	e [mm]
V 310/5 F		K3888-F	309,56	5,953	1,895	52	1,80	1,50	1,50
V 316/3 F		K5406	316,80	3,300	1,050	96	1,00	1,00	1,20
V 323/3 F		K5098	323,40	3,300	1,050	98	1,00	1,00	1,20
V 337/7 F		K3498-F	337,04	7,660	2,438	44	2,50	1,60	1,45
V 341/7 F		K3673-F	340,30	7,734	2,462	44	2,50	2,00	1,40
V 350/5 FK		K4909-FK	350,31	5,077	1,616	69	1,80	1,20	1,00
V 351/2 F		K5999-F	351,79	2,645	0,842	133	1,50	1,00	0,60
V 354/6 F		K3653-F	353,82	5,997	1,909	59	2,20	1,40	1,50
V 356/7 F		K3722-F	355,79	7,261	2,311	49	2,50	1,80	1,40
V 357/7 F		K3701-F	356,69	7,431	2,365	48	2,50	2,00	1,90
V 360/6 F		K3805-F	360,57	6,934	2,207	52	2,50	1,80	1,40
V 361/6 F		K3776-F	360,31	6,929	2,206	52	2,50	2,00	2,00
V 364/7 F		K3282-K	364,46	7,923	2,522	46	2,50	1,40	1,80
V 367/7 FK		K4463-FK	367,12	7,060	2,247	52	2,50	1,40	1,40
V 367/7 F		K3791-F	368,82	7,527	2,396	49	2,50	2,00	1,50
V 368/7 F		K4079-F	368,50	7,370	2,346	50	2,50	1,80	1,50
V 368/7 F		K3591-F	368,82	7,527	2,396	49	2,50	1,60	1,30
V 370/6 F		K3803-F	369,81	6,268	1,995	59	1,60	1,50	1,50
V 375/6 FK		K4746-FK	375,52	6,588	2,097	57	2,20	1,60	1,20
V 381/5 F XL		K6026-F	381,00	5,080	1,617	75	1,35	1,25	0,95
V 381/5 FK		K4773-FK	380,78	5,077	1,616	75	1,80	1,50	1,00
V 385/4 FK		K4759-FK	385,24	4,939	1,572	78	1,80	1,20	1,00
V 386/6 F		K4704-F	386,40	6,662	2,121	58	2,20	1,80	1,40
V 388/7 K		K3035-K	388,85	7,070	2,250	55	2,03	1,40	1,20
V 392/7 F		K3783-F	391,77	7,255	2,309	54	2,50	1,80	1,40
V 395/6 F		K5198-F	395,10	6,585	2,096	60	2,20	1,80	1,20
V 402/7 K		K3541-K	405,13	7,791	2,480	52	2,50	1,40	1,40
V 406/5 F XL		K6064-F	406,40	5,080	1,617	80	1,37	1,27	1,30
V 409/4 FK		K4834-FK	410,00	5,000	1,592	82	1,80	1,20	1,00
V 411/5 F		K3887-F	410,96	5,956	1,896	69	1,80	1,50	1,50
V 419/7 F		K3745-F	418,72	7,346	2,338	57	2,50	2,20	2,00
V 420/6 F		K3802-F	420,09	6,270	1,996	67	1,60	1,50	1,50
V 423/7 F		K3728-F	422,99	7,981	2,540	53	2,50	2,00	2,00
V 431/6 F		K3242-F	430,15	6,145	1,956	70	2,00	1,40	1,50
V 431/6 K		K3242-K	431,06	6,158	1,960	70	2,00	1,40	1,60
V 432/7 F		K3886-F	431,93	7,447	2,370	58	2,50	2,20	2,00
V 432/7 K		K3083-K	432,10	7,450	2,371	58	2,50	1,40	1,40
V 432/7 F		K3083-F	432,10	7,450	2,371	58	2,50	1,40	1,40
V 437/9 FK		K4720-FK	437,80	9,950	3,167	44	3,50	2,50	1,60
V 438/9 F L		K5095-F	438,15	9,525	3,032	46	3,20	1,80	1,20

Timing belts with special profiles - endless

SYNCHROFLEX® TIMING BELT (SFX)

V

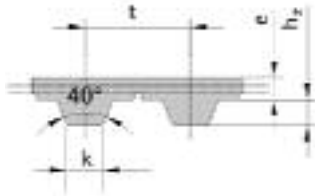

Order Example:

SYNCHROFLEX®-ZAHNRIEMEN 10 V 100 / 3 F
 Belt width in mm _____
 Type / Length code _____

Power transmission technology

Type	Imperial pitch	Shape No.	Length l [mm]	Pitch t [mm]	Module m	Number of teeth z	k [mm]	h ₂ [mm]	e [mm]
V 440/5	F	K3998-F	439,82	5,712	1,818	77	1,60	1,50	1,20
V 443/7	K	K3594-K	442,98	7,383	2,350	60	2,50	1,40	1,40
V 444/7	F	K4276-F	444,18	7,403	2,356	60	2,50	1,80	1,40
V 446/7	F	K3743-F	445,80	7,430	2,365	60	2,50	1,80	1,50
V 448/7	F	K3903-F	447,56	7,852	2,499	57	2,50	1,40	1,50
V 449/7	K	K2947-K	449,16	7,880	2,508	57	2,50	1,40	1,80
V 449/9	K	K3509-K	449,18	9,358	2,979	48	3,20	2,20	1,90
V 450/7	F	K3034-F	449,47	7,023	2,235	64	2,50	1,40	1,20
V 457/6	K	K3406-K	457,34	6,352	2,022	72	2,20	1,20	1,60
V 459/9	F	K3690-F	459,10	9,182	2,923	50	3,00	2,50	1,70
V 463/7	F	K3794-F	463,94	7,249	2,307	64	2,50	1,80	1,50
V 468/7	K	K3315-K	468,66	7,559	2,406	62	2,50	1,60	2,00
V 473/7	K	K3086-K	473,46	7,284	2,319	65	2,50	1,40	1,60
V 474/7	F	K3785-F	473,22	7,394	2,354	64	2,50	1,80	1,50
V 480/7	K	K3471-K	480,69	7,753	2,468	62	2,50	1,40	1,60
V 491/7	F	K3666-F	490,73	7,915	2,519	62	2,00	1,40	1,10
V 508/5	F	XL K6011-F	508,00	5,080	1,617	100	1,32	1,22	1,32
V 510/10F		K6142-F	510,00	10,000	3,183	51	3,50	2,50	1,60
V 511/9	F	K3347-F	511,43	9,471	3,015	54	3,00	2,50	2,00
V 513/8	K	K3223-K	513,88	8,860	2,820	58	2,80	1,60	0,00
V 514/9	K	K3411-K	514,25	9,183	2,923	56	3,20	2,20	2,00
V 515/7	F	K3826-F	515,24	7,577	2,412	68	2,50	1,80	1,60
V 515/9	FK	K4741-FK	515,86	9,553	3,041	54	3,50	2,50	1,40
V 516/7	F	K3680-F	516,56	7,947	2,530	65	2,50	1,40	1,30
V 522/6	F	K4084-F	522,49	6,295	2,004	83	2,50	1,40	1,40
V 532/9	F	K3638-F	532,50	9,509	3,027	56	3,20	2,20	2,00
V 537/7	F	K3088-F	537,88	7,910	2,518	68	2,50	1,40	1,40
V 546/7	F	K3830-F	546,42	7,806	2,485	70	2,50	1,80	1,50
V 548/2	F	K5661-F	548,64	2,540	0,809	216	1,00	0,70	0,60
V 552/6	F	K3703-F	552,46	6,278	1,998	88	2,20	1,20	1,20
V 555/7	FK	K4492-FK	555,43	7,823	2,490	71	2,50	1,80	1,30
V 563/9	F	K3897-F	563,76	9,720	3,094	58	3,20	1,80	2,00
V 567/5	F	K3974-F	567,25	5,971	1,901	95	2,00	1,50	1,50
V 570/9	F	K3840-F	570,71	9,205	2,930	62	3,00	2,50	2,00
V 571/9	F	L K6114-F	571,50	9,525	3,032	60	3,26	1,91	1,69
V 574/7	F	K3890-F	574,64	7,561	2,407	76	2,50	2,20	2,00
V 583/9	F	K3723-F	582,54	9,709	3,090	60	3,00	2,50	2,00
V 592/7	F	K3754-F	592,20	7,896	2,513	75	2,50	2,20	2,00
V 609/5	F	XL K5546-F	609,60	5,080	1,617	120	1,36	1,20	0,70
V 609/4	F	K6037-F	609,55	4,233	1,347	144	1,80	1,20	1,00

SYNCHROFLEX® TIMING BELT (SFX)

V

Order Example:

SYNCHROFLEX®-ZAHNRIEMEN 10 V 100 / 3 F

Belt width in mm _____
Type / Length code _____

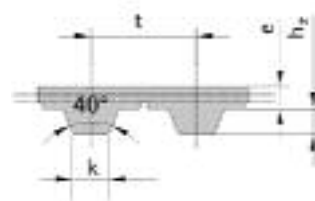

Type	Imperial pitch	Shape No.	Length l [mm]	Pitch t [mm]	Module m	Number of teeth z	k [mm]	h ₂ [mm]	e [mm]
V 620/6	FK	K3142-FK	620,24	6,969	2,218	89	2,50	1,40	1,30
V 620/6	F	K3142-F	620,24	6,969	2,218	89	2,50	1,40	1,50
V 623/9	F	K3206-K	623,62	9,744	3,102	64	3,20	1,60	1,50
V 626/6	F	K6255-F	626,50	6,265	1,994	100	1,60	1,50	1,50
V 628/6	F	K3782-F	628,30	6,283	2,000	100	2,20	1,80	1,80
V 629/9	F	K4593-F	629,50	9,992	3,181	63	3,50	2,50	2,00
V 635/5	F XL	K5394-F	635,00	5,080	1,617	125	1,32	1,20	0,60
V 651/7	F	K3297-F	651,51	7,239	2,304	90	2,50	1,40	1,60
V 685/5	F XL	K5821-F	685,80	5,080	1,617	135	1,36	1,20	0,70
V 686/9	F	K3971-F	686,74	9,538	3,036	72	3,20	1,80	1,50
V 698/9	FK	K4585-FK	699,02	9,986	3,179	70	3,50	2,50	1,60
V 728/15	K	K5667-K	728,50	15,500	4,934	47	4,70	2,30	1,60
V 758/8	FA	K3708-FA	757,21	8,508	2,708	89	3,00	2,50	2,40
V 760/8	F	K5665-F	759,88	8,538	2,718	89	3,00	2,50	1,80
V 779/2	F	K5680-F	779,78	2,540	0,809	307	1,00	0,70	0,60
V 818/6	F	K3853-F	818,33	6,935	2,207	118	2,50	1,80	1,60
V 829/8	F	K3831-F	828,48	8,630	2,747	96	3,00	2,50	2,00
V 850/4	F	K5782-F	850,75	4,032	1,283	211	1,30	1,20	1,90
V 853/5	F	K3770-F	853,14	5,966	1,899	143	1,60	1,50	1,30
V 859/6	F	K5328-F	859,40	6,095	1,940	141	2,44	0,92	0,90
V 862/13	F	K3764-F	861,38	13,252	4,218	65	3,20	2,80	2,50
V 870/9	F	K3867-F	868,95	9,655	3,073	90	3,00	2,50	2,00
V 889/5	F XL	K5601-F	889,00	5,080	1,617	175	1,80	1,20	1,00
V 901/9	F	K3777-F	900,13	9,185	2,924	98	3,00	2,50	2,50
V 910/10	F	K6155-F	910,00	10,000	3,183	91	3,50	2,50	1,60
V 912/7	F	K3661-F	911,71	7,473	2,379	122	2,50	1,60	1,50
V 914/12	F H	K5692-F	914,40	12,700	4,043	72	4,30	2,20	1,85
V 939/9	F	K3878-F	939,13	9,583	3,050	98	3,20	1,80	1,50
V 969/6	F	K5063-F	968,95	6,094	1,940	159	2,44	0,92	0,90
V 971/9	F L	K5354-F	971,55	9,525	3,032	102	3,25	1,90	1,40
V 978/9	F	K5486-F	978,04	9,980	3,177	98	3,50	2,50	0,00
V 990/9	F L	K5185-F	990,60	9,525	3,032	104	3,10	2,20	1,65
V 1000/9	F L	K5202-F	1000,13	9,525	3,032	105	3,10	2,20	1,65
V 1003/2	F	K6219-F	1003,33	2,073	0,660	484	0,60	0,42	0,80
V 1010/10	F	K6156-F	1010,00	10,000	3,183	101	3,50	2,50	1,60
V 1023/9	K	K3399-K	1023,77	9,307	2,963	110	3,20	2,20	2,00
V 1023/9	F	K3765-F	1022,23	9,293	2,958	110	3,00	2,50	2,50
V 1027/9	F	K4259-F	1026,78	9,420	2,998	109	3,00	2,50	2,00
V 1028/9	F L	K5589-F	1028,70	9,525	3,032	108	3,10	1,90	1,65
V 1052/15	F	K6018-F	1052,44	15,708	5,000	67	5,00	1,70	3,00

Timing belts with special profiles - endless

SYNCHROFLEX[®] TIMING BELT (SFX)

V

V-DL

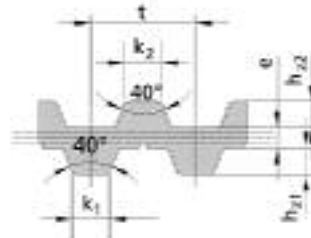
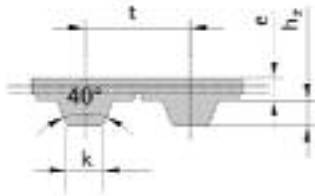

Power transmission technology

Type	Imperial pitch	Shape No.	Length l [mm]	Pitch t [mm]	Module m	Number of teeth z	k [mm]	h _z [mm]	e [mm]
V 1060/4	F	K6012-F	1059,68	4,975	1,584	213	1,80	1,20	1,00
V 1065/12	FK	K4676-FK	1066,30	12,694	4,041	84	4,00	2,20	1,40
V 1080/4	F	K5746-F	1080,58	4,032	1,283	268	1,32	1,20	0,70
V 1097/5	F XL	K5993-F	1097,28	5,080	1,617	216	1,37	1,27	1,30
V 1102/5	F XL	K5776-F	1102,36	5,080	1,617	217	1,80	1,20	1,00
V 1104/9	F L	K5435-F	1104,90	9,525	3,032	116	3,25	1,90	2,30
V 1106/2	F	K6260-F	1145,42	2,922	0,930	392	0,76	0,51	0,59
V 1110/10	F	K6143-F	1110,00	10,000	3,183	111	3,50	2,50	1,60
V 1140/10	F	K3823-F	1138,28	10,945	3,484	104	3,20	2,80	2,50
V 1149/4	F	K5871-F	1149,12	4,032	1,283	285	1,32	1,20	0,70
V 1152/9	F L	K5493-F	1152,53	9,525	3,032	121	3,10	1,90	1,65
V 1177/4	F	K5814-F	1177,34	4,032	1,283	292	1,30	1,20	0,90
V 1178/5	F XL	K5876-F	1178,56	5,080	1,617	232	1,80	1,20	1,00
V 1215/9	FA	K3316-FA	1213,42	9,334	2,971	130	3,00	2,50	2,00
V 1215/9	F	K5203-F	1213,42	9,334	2,971	130	3,20	1,80	2,00
V 1257/9	F L	K5310-F	1257,30	9,525	3,032	132	3,20	1,90	1,65
V 1270/12	F H	K5258-F	1270,00	12,700	4,043	100	4,45	2,18	2,01
V 1300/9	F	K5335-F	1300,65	9,425	3,000	138	3,00	2,50	2,00
V 1332/6	F	K3781-F	1331,15	6,279	1,999	212	2,20	1,80	1,80
V 1390/9	F L	K5449-F	1390,65	9,525	3,032	146	3,20	1,90	1,30
V 1423/9	F	K5495-F	1423,40	9,553	3,041	149	3,50	1,90	1,30
V 1529/6	F	K4866-F	1528,71	6,291	2,002	243	2,20	1,80	1,30
V 1563/9	F	K4035-F	1561,56	9,407	2,994	166	3,00	2,50	2,00
V 1584/5	F XL	K5600-F	1584,96	5,080	1,617	312	1,80	1,20	1,00
V 1635/9	F	K3340-F	1632,47	9,382	2,986	174	3,00	2,50	2,50
V 1637/9	F	K4582-F	1633,86	9,390	2,989	174	3,00	2,50	2,50
V 1676/12	F	K5262-F	1672,97	12,674	4,034	132	4,40	2,30	1,95
V 1778/12	F H	K5260-F	1778,00	12,700	4,043	140	4,40	2,30	1,40
V 1997/18	F	K5331-F	1997,04	18,840	5,997	106	6,50	4,00	3,00

Type	Imperial pitch	Shape No.	Length l [mm]	Pitch t [mm]	Module m	Number of teeth z	k ₁ [mm]	k ₂ [mm]	h _{z1} [mm]	h _{z2} [mm]	e [mm]
V 409/4	DL	K4834-DL	409,10	4,989	1,588	82	1,80	1,80	1,20	1,20	1,00
V 431/5	DL XL	K6038-DL	431,80	5,080	1,617	85	1,37	1,37	1,27	1,27	0,81
V 454/7	DL	K3460-DL	453,44	7,818	2,489	58	2,20	2,50	1,00	1,40	1,20
V 461/5	DL	K3760-DL	460,82	5,486	1,746	84	1,60	1,60	1,50	1,50	1,10
V 551/7	DL	K3304-DL	550,13	7,536	2,399	73	2,80	2,50	1,60	1,60	1,50
V 758/8	DLII	K3708-DLII	757,48	8,511	2,709	89	3,00	5,50	2,50	2,00	2,70
V 785/6	DL	K4592-DL	785,25	6,282	2,000	125	2,20	2,20	1,50	1,50	0,90
V 1215/9	DL	K3316-DL	1212,51	9,327	2,969	130	3,20	3,20	1,80	1,80	1,70
V 1357/6	DL	K3579-DL	1356,12	6,919	2,202	196	2,20	2,20	1,80	1,80	1,30
V 1635/9	DL	K3340-DL	1633,86	9,390	2,989	174	3,00	3,00	2,50	2,50	2,30
V 1635/9	DLII	K3340-DLII	1633,86	9,390	2,989	174	3,00	3,20	2,50	1,80	2,30